

# **EXELTECH**

*Manufacturer of True Sine Wave Power Inverters and Related Products*

## **PRODUCT CATALOG**

[www.exeltech.com](http://www.exeltech.com)

7317 Jack Newell Blvd North Fort Worth, Texas 76118-7100 voice- 817.595.4969 fax- 817.595.1290 toll free- 800.886.4683

# Table of Contents

<b>XP Series.....</b>	<b>1</b>
<b>MX Series.....</b>	<b>4</b>
<b>LC Series.....</b>	<b>14</b>
<b>STS System.....</b>	<b>24</b>
<b>NC Series.....</b>	<b>32</b>
<b>XO Series.....</b>	<b>42</b>
<b>MI Series.....</b>	<b>45</b>
<b>FC Series.....</b>	<b>47</b>
<b>KC Series.....</b>	<b>49</b>
<b>Company Profile.....</b>	<b>51</b>

Manufacturer of True Sine Wave Power Inverters and Related Products

## XP SERIES POWER INVERTERS



XP 125



XP 250



XP 600



XP 1100



XP 2000

Made in America, **EXELTECH XP SERIES INVERTERS** are the most affordable, reliable, lightweight and best regulated, true sine wave inverters available. The **XP SERIES** inverter will operate any AC load anywhere. Ultra lightweight, yet rugged enough for the most extreme mobile environments, the **XP SERIES** is available in 100Vac, 120Vac, or 230Vac in 50Hz, 60Hz or 400Hz for land, marine or military applications, worldwide.

- TRUE SINE WAVE
- 125 WATTS TO 2000 WATTS
- 12VDC TO 108VDC INPUT
- RACK MOUNT OPTIONAL
- REMOTE SWITCHING
- 21.5 YEARS MTBF



# XP SERIES POWER INVERTER SPECIFICATIONS

## OUTPUT POWER

MODEL	CONTINUOUS POWER	SURGE POWER	NO LOAD POWER	OUTPUT VOLTAGE	OUTPUT CURRENT	WEIGHT LBS.
XP-125	110W	125W	5W	100 +/-6%	1.1	2
XP-125	125W	150W	5W	117 +/-6%	1.1	2
XP-250	210W**	250W	6W	100 +/-6%	2.1	5
XP-250	250W**	300W	6W	117 +/-6%	2.1	5
XP-250	250W**	300W	7W	230 +/-6%	1.1	5
XP-600	510W**	1000W	8W	100 +/-6%	5.1	6.5
XP-600	600W**	1100W	8W	117 +/-6%	5.1	6.5
XP-600	600W**	1100W	9W	230 +/-6%	2.7	6.5
XP-1100	950W**	1900W	20W*	100 +/-6%	9.5	10
XP-1100	1100W**	2200W	20W*	117 +/-6%	9.5	10
XP-1100	1100W**	2200W	20W*	230 +/-6%	4.8	10
XP-2000	1700W**	3400W	12W	100 +/-2%	16.7	15
XP-2000	2000W**	4000W	12W	120 +/-2%	16.7 (15) <sup>1</sup>	15
XP-2000	2000W**	4000W	12W	230 +/-2%	8.7 (7.8) <sup>1</sup>	15

\*10W with X2 option , \*\*remote switchable, <sup>1</sup>12Vdc rating-1800W

## MECHANICAL

Case size (HxWxD)

125W case size= 2.16" X 4.93" X 7.90"  
(2 lbs)  
250W case size= 2.77" X 5.23" X 12.03"  
(5 lbs)  
600W case size= 3.57" X 7.69" X 12.10"  
(6.5 lbs)  
1100W case size= 3.57" X 7.69" X 15.05"  
(10 lbs)  
2000W case size= 4" X 9" X 18"  
(15 lbs)

## OPTIONS

XP Options:

- conformal coating (07 option)
- low idle current drain (02 option)\*
- circuit board with heat sink only (04 option) many other options available for OEM applications, consult factory.

\*1100 watt only

## INPUT POWER

MODEL	INPUT VOLTAGE	MINIMUM <sup>1</sup> (TYPICAL)	SYSTEM (TYPICAL)	MAXIMUM <sup>1</sup> (TYPICAL)	TYPICAL EFFICIENCY @ FULL POWER	PEAK EFFICIENCY @ 1/3 POWER
XP-125/250/600/1100	12V	10.4/10.6*	13.8V	16.5V	85%	87%
XP-125/250/600/1100	24V	19/21V*	27.6V	33V	87%	89%
XP-125/250/600/1100	32V	26.5/28V*	36.8V	44V	88%	90%
XP-125/250/600/1100	48V	41.5/42.5V*	55.2V	62V	87%	89%
XP-125/250/600/1100	66V	57.5/58.5V*	75.9V	91V	88%	90%
XP-125/250/600/1100	108V	94/95V*	125V	149V	87%	90%
XP-2000**	12V	10.4/10.8V*	13.8V	15V	>80%	>83%
XP-2000	24V	20.8/21.6V*	27.6V	30V	>88%	>90%
XP-2000	48V	41.6/43.2V*	55.2V	60V	>88%	>90%
XP-2000	66V	57.2/59.4V*	75.9V	82.5V	>88%	>90%
XP-2000	108V	93.6/97.2V*	124.2V	135V	>88%	>90%

\*Indicates typical cut-off voltage/warning buzzer voltage; <sup>1</sup> +/- 3%; \*\*12Vdc rating-1800W

## PROTECTION CIRCUITRY

\*Over Voltage: Shut off at maximum input voltage, per input conditions. Automatic reset upon fault correction.

\*Under Voltage: Shut off at minimum input voltage, per input conditions

\*Thermal: Shuts off due to over temperature condition. Warning buzz 5 C before shut off

Output Short: Unit shuts off (manual reset)

\*Automatically reset

## GENERAL

CONDITIONS	MINIMUM	TYPICAL	MAXIMUM
WAVEFORM	-	SINUSOIDAL	-
VOLTAGE OUTPUT	-5%	NOMINAL	+5%
LINE REGULATION	-	0.1%	0.5%
LOAD REGULATION	-	0.5%	1%
DISTORTION	-	1.5%	2%
FREQUENCY	-0.1%	NOMINAL	+0.1%

See [www.exeltech.com](http://www.exeltech.com) for more data regarding XP Series inverters.

## ENVIRONMENTAL

Temperature: -25 to 30 C full power derated 20% per 10 C, above 30 C.

Humidity: 5 to 95% non condensing

Altitude: -200 to 10k feet full power, derated above 10k

Audible Noise: Less than 45dbA

Cooling: 600W/1100W/2000  
Thermostatically controlled forced air. 125W/250W convection cooled.

Finish: Painted aluminum

Warranty: Full year, parts/labor

# XP SERIES PART NUMBERING SYSTEM

**EXELTECH XP SERIES**    XP    \_ - \_ - \_ - \_ - 1 - \_  
**MODEL NUMBER**

**Step 1:** Model number always starts with XP.

**Step 2:** To designate wattage enter the single character code  
 1 for 125, 2 for 250, 6 for 600, K for 1100, X for 2000

**Step 3:** To designate output voltage enter the single character code from the Vac chart

Vac OUTPUT VOLTAGE CHART			
AC Volts	100	120	230*
Designation	0	1	3

\*Not available in 125watt models

**Step 4:** To designate input voltage enter the single character code from the Vdc chart

Vdc INPUT VOLTAGE CHART						
DC Volts	12	24	32	48	66	108*
Designation	1	2	B	4	E	I

\*Not available in 2000watt models

**Step 5:** Output frequency is designated by using the first number of the frequency  
 5 for 50Hz, 6 for 60Hz and 4 for 400 Hz

**Step 6:** This designates revision level (For EXELTECH use only).

**Step 7:** To designate option, enter the code from the option chart below. If no option is required please leave it blank.

OPTION CHART	
Option	Code
Conformal coating	07
Low idle current drain	02*
Circuit board with heat sink only	04**
50MS transfer relay	20***

\* available thru a distributor only(only on XP1100W)

\*\*available for OEM's only

\*\*\*available on XP600 and XP1100 only

**EXAMPLE:** XP600 with  
 117Vac output, 12Vdc input,  
 60Hz with the conformal  
 coating option would require  
 the following model number:  
**XP6-1-1-6-1-07**



## MX SERIES POWER INVERTERS



MX SERIES FAMILY

- **N+1 REDUNDANT**
- **EXPANDABLE**
- **REMOTE SWITCHING**
- **TRUE SINE WAVE**
- **“HOT” INSERTABLE**
- **1000 WATT MODULES**
- **OPTIONAL SNMP**

**EXELTECH** manufactures the world's first truly **redundant, modular** inverter system; the **most reliable** inverter system available. No single malfunction will cause the inverter system to fail. **Modules are “hot” insertable.** Power levels are **expandable**, and modules can be added or replaced **without interruption in power** to your critical loads.

The MX system can be configured for **power levels from 1 to 20KW with 120 Vac** output. Up to 40KW at 240 Vac bi-phase or 60KW at 208 Vac 3 phase with many input and output voltages also available.

A control card and any number of additional 1000 Watt power modules combine to make a standard inverter. This type of system can be expanded as power requirements increase, and upgraded to be N+1 redundant as desired.

The MX system is **extremely compact and lightweight.** Power modules weigh only 7 lbs. Each.

Output voltage is precisely regulated, so that no measurable voltage change occurs on the output as input voltage fluctuates. Similarly, less than 0.5 volt change in output voltage will occur when the output load varies from 0 to 100% of rated power. With distortion of 2% maximum, this inverter offers **the cleanest sine wave power available.**

Models are available which cover all standard battery systems. Custom models can be designed to meet your specific input voltage requirements.



# MX SERIES MODULE DESCRIPTION

The *Exeltech MX* Series of inverters is a modular system which can be assembled in many combinations to afford the user infinite flexibility. Options such as AC distribution, AC disconnect, metering, DC disconnect, DC distribution, transfer switch and maintenance bypass switch are also available; (see accessories).

The building blocks of the system are as follows:

- 1.) Power Module - A 1000 Watt slave power inverter. It requires drive signals from a Master Module or Control Card as described below. This module is the backbone of the inverter system.
- 2.) Master Module - A 1000 Watt power inverter which contains all the electronics necessary to operate; requires an enclosure to provide connections to the battery and AC output. It can also operate up to 19 slave Power Modules. If this module is used, the system cannot be fully redundant.  
***All MX systems require either a master module or at least one control card.***
- 3.) Control Card - Generates all the signals necessary to operate up to 20 Power Modules. The card itself will not generate any AC output power nor does any power flow through it. This card can be paralleled with another Control Card to generate a redundant set of control signals to form the basis of a completely redundant inverter system.  
***All MX systems require either a master module or at least one control card.***
- 4.) Alarm Card - Can be used in conjunction with a redundant or non redundant inverter to provide various alarm output signals via LED's and alarm contact closures. Must be included in redundant systems to detect failure of control card.
- 5.) Transfer Switch - Provides the same functions as the alarm card, plus provides a relay to transfer AC power to the load, from either the inverter or the utility input. Use only with systems up to 4KW N+1.

The above modules can be placed in the following enclosures; Installations can either be free standing or in standard relay racks.

- 1.) 19" cage assembly - Compatible with a 19" relay rack. The smallest cage which can contain a redundant system. Available in the following configurations:
  - 19A - Basic configuration for a redundant system. Holds up to 4 Power Modules, 2 Control Cards and either a Transfer Switch, System Monitor Card or an Alarm Card.
  - 19B - Used as an expansion rack or may be used as an expandable, non redundant inverter, up to 5 KW.  
***This configuration will not accept X-fer Switch, alarm card or control cards.***
- 2.) 23" cage assembly - Compatible with a 23" relay rack.
  - 23A - Basic configuration for a redundant system. Holds up to 5 Power Modules, 2 Control Cards and either a Static Transfer Switch, Transfer Switch, System Monitor II or an Alarm Card.
  - 23B - Used as an expansion rack or may be used as an expandable, non redundant inverter, up to 6 KW.  
***This configuration will not accept X-fer Switch, alarm card or control cards.***
- 3.) 7" cage assembly - for 1 or 2KW systems when redundancy is not required.
  - 7C - Consists of 1 Transfer Switch and 1 Master Module.  
***This configuration will not accept an alarm card or control cards.***
  - 7B - Expandable up to 2KW. 1 Master Module and 1 Power Module.  
***This configuration will not accept X-fer switch, alarm card or control cards.***
- 4.) 9" cage assembly- for 1-3KW systems when redundancy is not required.
  - 9C - Consists of Transfer Switch, 1 Master Module and 1 Power Module.  
***This configuration will not accept an alarm card or control cards.***
  - 9B - Expandable up to 3KW. 1 Master Module and 2 Power Modules.  
***This configuration will not accept X-fer Switch, alarm card or control cards.***

# MX SERIES SYSTEM DESCRIPTION

The *Exeltech MX* Series of inverters is available in three basic architectures; redundant, upgradable and expandable. Different options and sizes are available to fit varying applications. As a benefit of the *MX* series modular design, power levels are expandable in any system, as power requirements increase.

1.) **N+1 Redundant-Expandable Inverter System**: For applications where reliability and maintainability are paramount, the N+1 redundant system offers the most cost effective method of achieving redundancy and the ability to maintain the system while loads remain on line. All cards (except 12 Vdc) are "hot" insertable to allow maintenance without interrupting power to critical loads. Designing the power level with N+1 number of power modules, allows for redundancy without necessitating the purchase of a duplicate system. (An A/B Buss option is available, which adds to system reliability).

**A redundant system consists of:**

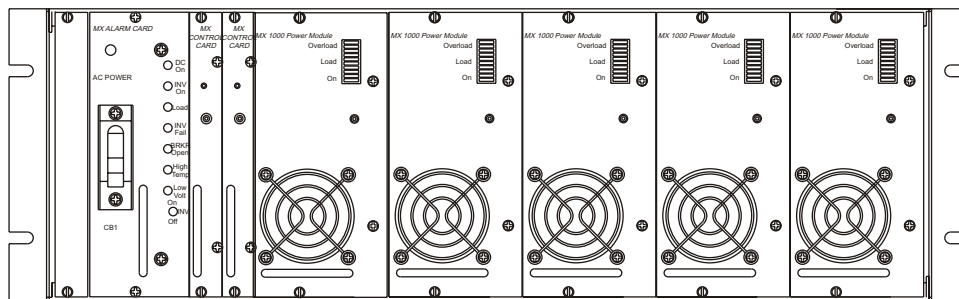

**1 ea. Alarm Card or System Monitor Card**  
part # H (100 Vac)  
A (120 Vac)  
B (120 Vac)  
C (120 Vac)  
F (230 Vac)

**2 ea. Control Cards**  
part # LL (100 Vac)  
CC (120 Vac)  
EE (230 Vac)

**At least 3 Power Modules**  
part # P (100 Vac)  
R (230 Vac)

**1 ea. Cage assembly**  
part # 1A (19" cage)  
2A (23" cage)

**Options: 1 ea. X-fer switch**  
part # G (100 Vac)  
S (120Vac)  
X (120 Vac)  
Z (230 Vac)

**X-fer switch includes alarms and replaces the alarm card.**

**expansion rack**  
part # 1B (19" cage)  
2B (23" cage)

**...integrates with rack A for accommodating additional power modules, up to total rating of 20KW. Additional control cards and a larger X-fer switch may be required. Please call the factory for assistance.**

2.) **Upgradable Inverter System**: The *Upgradable system* offers the flexibility to add a X-fer switch or alarm card and Full Redundancy for future requirements. A minimum system with as little as one control card and one power module can be upgraded in the future to include additional power modules, X-fer switch or alarm card and an additional control card for full redundancy (see figure II).



# MX SERIES SYSTEM DESCRIPTION

Figure II.

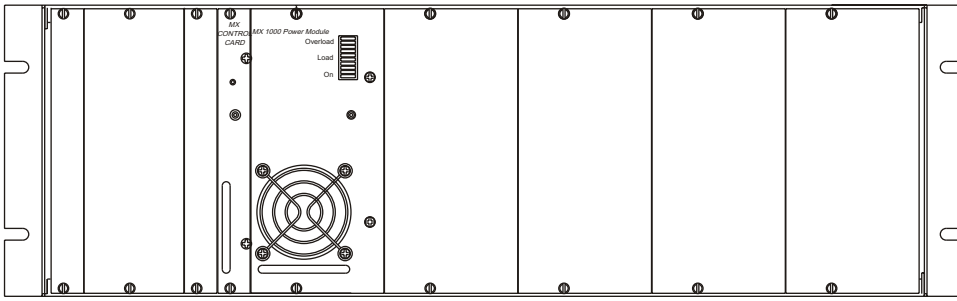

1 ea. Cage assembly  
part # 1A (19" cage)  
2A (23" cage)

**Options:**

- 1 ea. X-fer Switch  
part # G (100 Vac)  
S (120 Vac)  
X (120 Vac)  
Z (230 Vac)
- 1 ea. Alarm Card  
part # H (100 Vac)  
A (120 Vac)  
B (120 Vac)  
C (120 Vac)  
F (230 Vac)

- 1 ea. Control Card  
part # L\*(100 Vac)  
C\*(120 Vac)  
E\*(230 Vac)
- 1 ea. Power Module  
part # P (100 Vac)  
P (120 Vac)  
R (230 Vac)

3.) **Expandable inverter system:** This configuration can be used as an independent inverter system (figure III), or to expand power levels of existing *MX* systems (see stacked systems). By using one master module, a system may be expanded to include a X-fer switch and additional power modules (see figure IV). 1KW inverters with a X-fer switch use the 7" or 9" (part # 7C, 9C) cage. 1KW, 2KW and 3KW inverters without a X-fer switch use the 7" or 9" (part number 7B, 9B) cage assembly.

Figure III.

- 1 ea. Cage assembly\_  
part # 1B (19" cage)  
2B (23" cage)  
7B (7" cage)  
9B (9" cage)  
expansion rack  
(see stacked  
systems)
- 1 ea. Cage assembly  
part # 1A (19" cage)  
2A (23" cage)  
7C (7" cage)  
9C (9" cage)

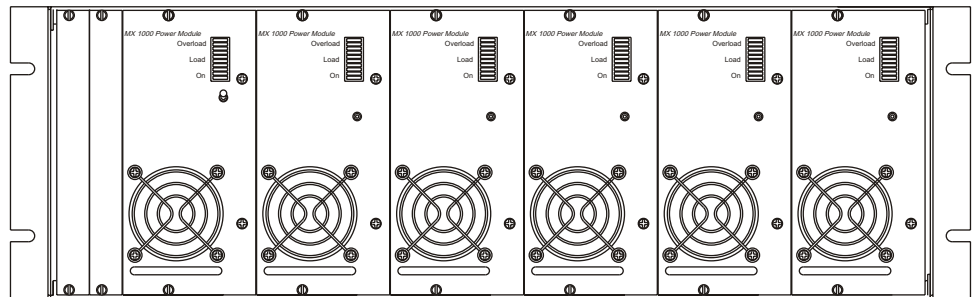

**Options:**

- 1 ea. X-fer Switch  
part # G (100 Vac)  
S (120 Vac)  
X (120 Vac)  
Z (230 Vac)
- 1 ea. Master Module<sup>1</sup>  
part # Q\* (100 Vac)  
M\* (120 Vac)  
N\* (230 Vac)

- Up to 5  
Power Modules  
part # P (100 Vac)  
P (120 Vac)  
R (230 Vac)

Figure IV.

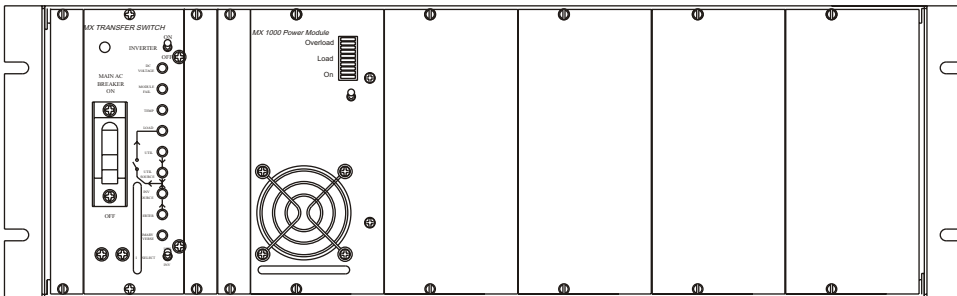

<sup>1</sup> Alarm card is not an option on this configuration

# MX SERIES SYSTEMS DESIGN CHART

MX SYSTEMS DESIGN CHART								
SYSTEMS REQUIRED	CAGE ASSY SIZE AND CONFIG.	Use X-fer or Alarm Card		Use CC or MM		POWER MODULE	AVAIL C- Current F- Future	
		X-FER SWITCH		ALARM CARD	CONTROL CARD			MASTER MODULE
		100Vac	G	H	L* or LL			Q*
		120Vac	X or S	A, B or C	C* or CC			M*
230Vac	Z	F	E* or EE	O*	R			
Redundant Upgradable 19" Cage	1A	0 or 1 <sup>1,4</sup>	0 or 1 <sup>1,4</sup>	0, 1, 2 <sup>5</sup>	0	up to 4 <sup>3</sup>	C	
Redundant Upgradable 23" Cage	2A	0 or 1 <sup>1,4</sup>	0 or 1 <sup>1,4</sup>	0, 1, 2 <sup>5</sup>	0	up to 5 <sup>3</sup>	C	
Expandable 19" Cage	1A	0 or 1	0	0	1	up to 3	C	
Expandable 23" Cage	2A	0 or 1	0	0	1	up to 4	C	
Expandable 7" Cage	7B	0	0	0	1	0 or 1	C	
Expandable 9" Cage	9B	0	0	0	1	up to 2	C	
Expandable 19" Cage	1B	0	0	0	1	up to 4	C	
Expandable 23" Cage	2B	0	0	0	1	up to 5	C	
Expandable 7" Cage	7C	0 or 1	0	0	1	0	C	
Expandable 9" Cage	9C	0 or 1	0	0	1	0 or 1	F	
Split Phase 19" Cage	1E	0	0	0	2	0 or 2	F	
Split Phase 23" Cage	2E	0	0	0	2	0,2,4	F	
Split Phase 7" Cage	7E	0	0	0	2	0	C	
3 Phase 19" Cage	1F	0	0 or 1 <sup>2</sup>	0	3	0	F	
3 Phase 23" Cage	2F	0	0 or 1 <sup>2</sup>	0	3	0 or 3	C	
3 Phase 9" Cage	9F	0	0	0	3	0	C	

<sup>1</sup> 1 per phase

<sup>2</sup> Alarm with a subset of functions (multi-phase option A13)

<sup>3</sup> System is not fully redundant with less than 3 power modules

<sup>4</sup> Minimum 1 Alarm Card or 1 X-fer Switch required for redundant system

<sup>5</sup> Minimum 2 Control Cards for redundant system.

**NOTE: Any modification to any Stack System must be performed in the factory.**

# MX SERIES POWER INVERTER SPECIFICATIONS

## OUTPUT POWER

CONTINUOUS POWER	SURGE POWER (3 seconds)	NO LOAD POWER	OUTPUT VOLTAGE	OUTPUT CURRENT	WEIGHT LBS.
1000W	2200W	20W	230+/-6%	4.3	7.5
1000W	2200W	20W	117+/-6%	8.6	7.5
1000W	2200W	20W	100+/-6%	10.0	7.5

## INPUT

MODEL VOLTAGE	MINIMUM (TYPICAL)	SYSTEM (TYPICAL)	MAXIMUM (TYPICAL)	TYPICAL EFFICIENCY @ FULL POWER	PEAK EFFICIENCY @ 1/3 POWER
12V	10.4/10.6*	13.8V	17V	85%	87%
24V	19/21V*	27.6V	34V	87%	89%
32V	26.5/28V*	36.8V	45V	87%	89%
48V	41.5/42.5V*	55.2V	62V	87%	89%
66V	57.5/58.5V*	75.9V	94V	88%	90%
108V	94/95V*	124V	149V	88%	90%

\*indicates typical cut-off voltage/warning buzzer voltage

## GENERAL

CONDITIONS	MINIMUM	TYPICAL	MAXIMUM
WAVEFORM	-	SINUSOIDAL	-
LINE REGULATION	-	.1%	.5%
LOAD REGULATION	-	.3%	.5%
DISTORTION	-	1.5%	2%
FREQUENCY*	-.1%	NOMINAL	+1%

\*50, 60, 400Hz nominal

See [www.exeltech.com](http://www.exeltech.com) for more data regarding MX Series inverters.

## PROTECTION CIRCUITRY

Over Voltage:	Shutoff at maximum input voltage, per input conditions.
Under Voltage:	Shutoff at minimum input voltage, per input conditions.
Thermal:	Shuts off due to over temperature condition. Warning buzz 5 C before shutoff
Output Short:	Unit shuts off: Circuit breaker protected and electronically limited.

## ENVIRONMENTAL

Temperature:	-25 to 40 C full power, derate 20% per 10 C. Above 40 C.
Humidity:	5 to 95% non-condensing
Altitude:	-200 to 10k feet full power, derated above 10k
Audible Noise:	Less than 45dbA
Cooling:	1KW-Thermostatically controlled forced air
Finish:	Polyurethane base paint
Warranty:	Full year parts and labor.

## MECHANICAL

Four case sizes are available; all are: 7" high X 15" deep.	
19 inch Wide:	(includes hardware for rack or shelf mounting)
23 inch Wide:	(includes hardware for rack or shelf mounting)
9.97 inch Wide:	(for 1 to 3KW applications; surface mounting only)
7 inch Wide:	(for 1 or 2KW applications; surface mounting only)
Available in other sizes including metric. Call factory for sizes.	

# MX SYSTEMS MONITOR 2 CARD

The System Monitor 2 card is the newest of the monitoring card family and has more features than the original system monitor card. It will monitor all the alarms, AC and DC voltage and current, and AC frequency. Multi-phase systems can also be monitored with all the information available from the front panel LCD or via an Ethernet connection. The card can handle all of the system monitoring and alarm reporting that is required for a MX system.

## Features

The System Monitor 2 card is available in three power levels, 5KW, 10KW, and 20KW. It is available for single, split, and 3 phase systems. It will report AC voltage, current, and frequency, along with DC voltage, and current. All the standard alarms are also monitored and reported via the front panel LCD or the Ethernet connection. It can switch to the secondary control card (when present) if the primary card fails.

## Remote Monitoring

The System Monitor 2 status can be monitored over Ethernet in two ways. The first way to monitor the system is with SNMP. An "mib" file is provided and can be loaded into any SNMP monitoring software. Another program is provided to monitor the system and needs to be loaded onto a PC connected to the System Monitor 2's network. This program displays the status of the system and also logs the data to be viewed at another time. A DHCP server is required for the system to acquire an IP address.

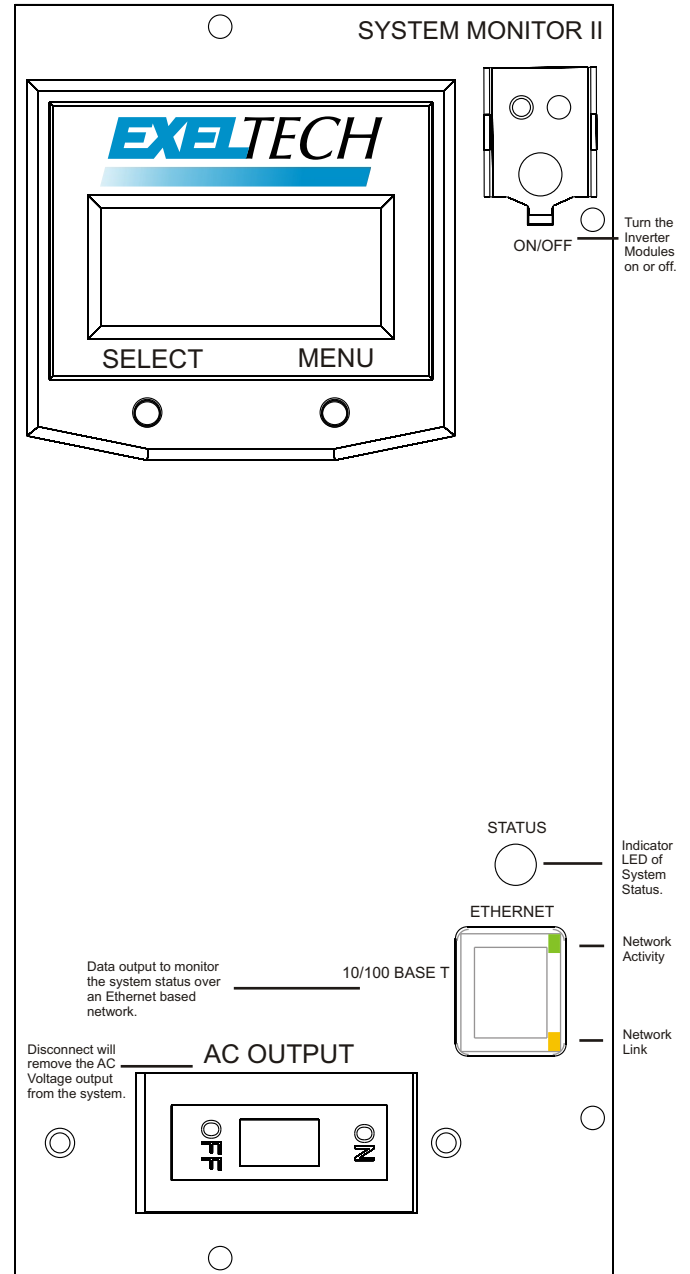

# MX SOLID STATE TRANSFER SWITCH

## Features

- Solid State
- Zero Switching time
- Modular Design
  - Single phase in 5, 10, 20KW
  - Split phase in 10, 20, 40KW
  - 3 Phase 15, 30, 60KW
- SNMP Monitoring
  - AC Amps
  - AC Volts
  - DC Amps
  - DC Volts
- Alarm Conditions
  - Load on alternate
  - Inverter alarms (if equipped)
- Fast AC Failure Detection (< 2 ms)
- Primary selection via front panel switch
- Optional generator start

## Operation

The Exeltech Solid State Transfer Switch sets a new standard in power density and alarm capabilities. Its modular design is available in 3 power levels, 5, 10 and 20KW, which can be linked together to provide single, split, and 3 phase systems. The Switches can communicate on a SNMP protocol via TCP/IP that provides data on AC volts and amps of both the primary and secondary sources. If linked to an MX inverter system it will perform all the normal functions of the required alarm card plus communicate DC volts and amps, all inverter alarms including inverter fail, module fail, and over temperature. If the inverter is so equipped, the switch will report both DC Bus A and Bus B Voltage. Additionally, the switch can report combined Major and Minor alarms via SNMP and form C contacts. The minor alarm is triggered with any alarm, the major alarm is only triggered with complete loss of AC Voltage to the load or when a complete loss is imminent.

All good to good transfers are synchronous and performed at zero crossing. The switch will operate on the user selectable primary source until the primary source fails or operates out of limits. It will switch to the secondary source in less than 4 ms worst case. If the primary returns to normal limits, the switch will wait 15 sec for stabilization, monitor the primary and secondary source, upon assuring they are in phase, it will switch at the next available zero crossing.

The status of all available alarms, status, and measurements are available via a 2 X 8 LCD display. It is highly recommended that an Exeltech maintenance bypass switch be used in conjunction with this or any other solid state transfer switch. This switch can be used with Exeltech inverters or between any 2 AC Sources whether they be inverters, generators or utility sources.

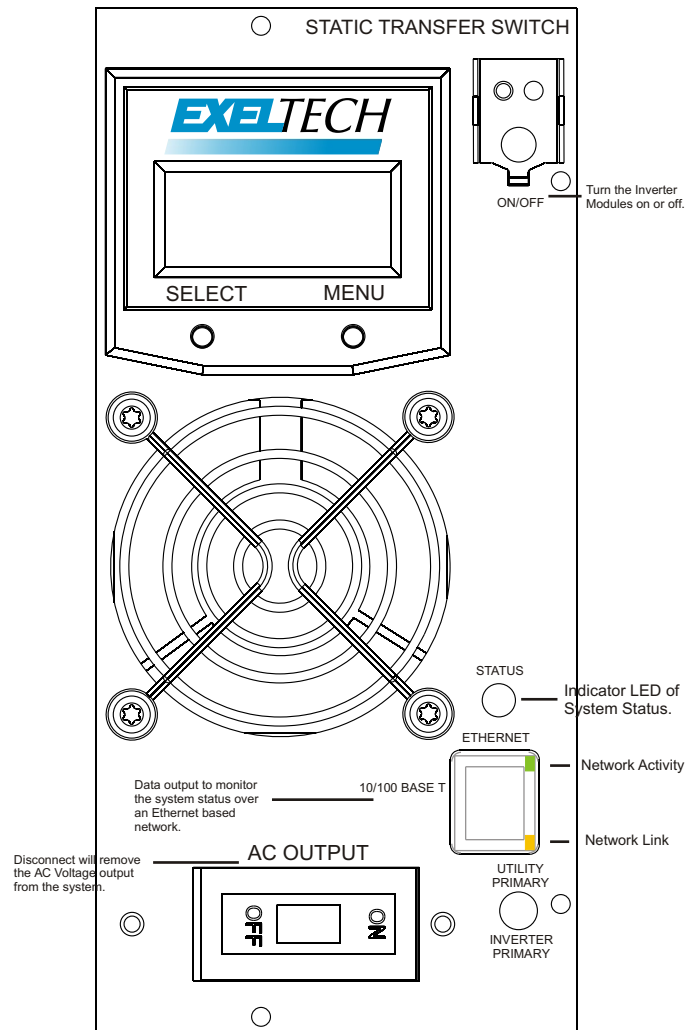

Voltage Transfer Set Point ( 120Vac )  
 Low voltage settings: 100Vac  
 High voltage settings: 130Vac

# MX SERIES SYSTEM PART NUMBER

Use the Design Chart to formulate the 15 digit model number.

## EXELTECH MX SERIES

### MODEL NUMBER

**Step 1:** Enter the two character code for cage assembly size and configuration.

**Step 2:** When a transfer switch or alarm card is used, enter the single character code for that card. 2nd and 3rd characters designate option level of transfer switch or alarm card. Enter 00 for standard module, if no alarm card or transfer switch use "B" configuration backplane, enter (\*\*\*)

**Step 3:** Alpha character assigned by EXELTECH to represent changes or revision levels in racks, alarm cards, or transfer switch. Enter (-). EXELTECH will assign revision level. See revision level chart on [www.exeltech.com](http://www.exeltech.com) for the most current revision list.

**Step 4:** Enter the two character code for Control Card(s) or Master Module. There is not an application where both are used. Enter (M\*) or (C\*) if only one is used.

**Step 5:** To designate power level, enter the number of power modules required. Redundant systems require continuous load rating plus one additional power module(\* if none used).

**Step 6:** To designate output voltage of the power module required, enter the single character code(\* if none used).

**Step 7:** Single alpha character assigned by EXELTECH represents changes or revision levels in Control Cards, Master Modules, or Power Modules. Enter (-). EXELTECH will assign revision level. See revision level chart on [www.exeltech.com](http://www.exeltech.com) for the most current revision list.

**Step 8:** To designate input voltage, enter the single character from the VDC voltage chart below.

Vdc INPUT VOLTAGE CHART						
DC Volts	12	24	32	48	66	108
Designation	1	2	B	4	E	I

**Step 9:** Output frequency is designated by using the first number of the frequency (5for 50Hz, 6 for 60Hz, 4 for 400Hz).

**Step 10:** For options, enter two digit code. If no option, enter (00).

**EXAMPLE:** A redundant system with an alarm card, to fit a 23" wide cage, for powering a 4000 watt continuous load, at 120Vac, 60Hz with 48Vdc input would require the following model number...

**2AA00ACC5P-4600**



# MX SERIES MODULE PART NUMBER

## EXELTECH MX SERIES MODULE NUMBER

MX - - - - -

**Step 1:** Model number always starts with MX.

**Step 2:** To designate a cage assembly, enter the two character code from the design chart. When ordering a power module or master module, enter a "K". If ordering any other module, enter an asterisk(\*).

**Step 3:** To designate the type of module, enter the single character code from the design chart. To designate cage assembly, enter an asterisk(\*).

**Step 4:** To designate input voltage, enter the single character code from the **Vdc INPUT VOLTAGE CHART** below. If ordering an alarm card, transfer switch or cage assembly, enter an asterisk(\*).

Vdc INPUT VOLTAGE CHART						
DC Volts	12	24	32	48	66	108
Designation	1	2	B	4	E	I

**Step 5:** Output frequency is designated by using the first number of the frequency(5 for 50Hz, 6 for 60Hz, 4 for 400Hz). If ordering a transfer switch, alarm card, power module or cage assembly, enter an asterisk(\*).

**Step 6:** This space designates current revision level, and is for EXELTECH use only. If no revision is in use for this module, no number or character will be used.

**Step 7:** To designate option, enter the code from the option chart below. If no option is required please leave blank.

OPTION CHART	
Option	Code
Conformal coating	07
Low idle current	08

**MODULE EXAMPLES:** A 12Vdc, 120Vac, 60Hz master module would require the following module number...

**MXK-M-1-6-1**

A 48vdc, 120Vac, 60Hz power module with conformal coating option would require the following module number...

**MXK-P-4-\*-1-07**

**CAGE ASSEMBLY EXAMPLE:** A 19" redundant cage, 120Vac would require the following module number:

**MX1A-\*-\*-2**

Manufacturer of True Sine Wave Power Inverters and Related Products

## LC SERIES POWER INVERTERS



- **N+1 REDUNDANT**
- **EXPANDABLE**
- **REMOTE SWITCHING**
- **TRUE SINE WAVE**
- **“HOT” INSERTABLE**
- **2000 WATT MODULES**
- **OPTIONAL SNMP**

Exeltech's LC series inverter systems are equipped with 2KW power modules, this now provides double the output power within similar space requirements as are top selling MX series inverters. Modules are "hot" insertable, power levels are expandable, and modules can be added or replaced without interruption in power to your critical loads.

The LC system can be configured for power levels from 2KW to 60KW single phase with 120VAC, 277VAC or 230VAC outputs. Up to 120KW at 240VAC bi-phase or 180KW at 208VAC or 480VAC three-phase with many input and output voltages also available.

A monitoring module plus any number of additional 2KW power modules combine to make a standard LC inverter. This type of system can be expanded as power requirements increase, and upgraded to be N+1 redundant as desired. The LC system can be configured with Exeltech's static transfer switch and maintenance bypass switch up to 20KW per phase. Also an optional customer interface cage with up to 5 DC breakers is available.

The LC system is extremely compact and lightweight. Power modules weigh only 9 lbs each and are equipped with LCD screens for quick access of system data.

Output voltage is precisely regulated, so that no measurable voltage change occurs on the output as input voltage fluctuates. Similarly, less than 0.5 volt change in output voltage will occur when the output load varies from 0 to 100% of rated power. With distortion of 2% maximum, this inverter offers the cleanest sine wave power available.

# LC SERIES MODULE OVERVIEW

The LC Series inverters are a modular design and allows each system to be tailored for specific needs. Systems can range in output power, input voltage, redundancy, and a variety of other options. This is done by selecting different combinations of modules to create a LC inverter system.

## 1.2.1 Power Module Cage Assembly

The cage assembly can be designed to accept DC input of either positive or negative. It will house from 1 to 6 inverter power modules resulting in a system output of up to 12,000 Watts. It will also house an optional monitoring module (recommended). The left most power module is the system's master module. The next power module to the right is the system's redundant (backup) master module. For redundant operation the system MUST include a monitoring module. The monitoring module is required to initiate a transfer of control to the backup master module.

## 1.2.2 Power Modules

The power module is the backbone of the LC inverter system and is the majority of the modules in all systems. Each module is capable of producing 2000 Watts of continuous output power. Each module can perform all of the functions to operate as a system's master module. The module will only perform the system master function when placed in the power module cage assembly location identified in the previous section. Each power module is equipped with an LCD display that can show power module status information as well as system status information.

## 1.2.3 Monitoring Module

The monitoring module provides a visual representation of different alarms created by the system. Each monitoring module has an ON/OFF switch for the system. If a monitoring module is not used the remote switch must be used to turn the system on and off. A monitoring module is required to detect a master power module failure and switch to the secondary master power module if it is available. There are a few different options available to monitor the LC inverter system.

### 1. Alarm Card:

With the alarm card, system monitoring is basic and is seen manually through power module LCD displays. Pre set alarms (Alarm1/Minor & Alarm 2/Major) are provided via dry form C relay contacts on the inverter systems backplane. Use of the other connections on the back plane may result in damage to the module or system.

### 2. Monitor Card:

With the monitor card, system data is more detailed and can be seen either manually through power module LCD displays or through Ethernet connection which allows for remote monitoring of system data. Each phase's information can be reported via the Ethernet connection. The data can be sent to a PC to be viewed and logged or reported via SNMPv2 or an optional secure SNMPv3. Programmable alarms (Alarm1/Minor & Alarm 2/Major) are provided via dry form C relay contacts on the inverter systems backplane. Product Status is used to program alarms. Use of the other connections on the back plane may result in damage to the module or system.

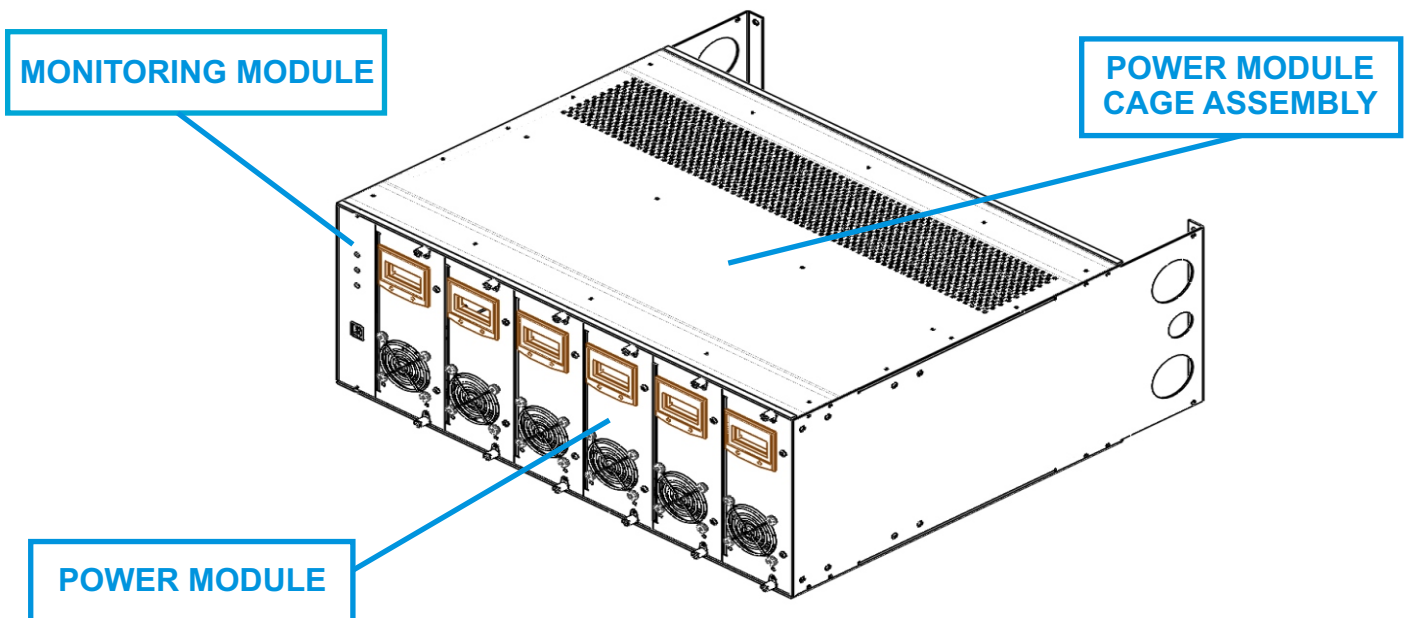

# LC SERIES SYSTEM OVERVIEW

The LC system can be configured from 2,000 to 12,000 Watts (1 to 6 power modules), with or without an optional monitoring module (highly recommended). With the monitoring module and a sufficient number of power modules, the system provides N+1 redundancy.

## **Remote On/Off Switch:**

A set of terminals are provided to turn the inverter system on and off from a remote location. The connection for the remote switch is on a remote alarm connector located under the rear access cover. Connect battery negative 'Bat(-)' to the 'Sw1' terminal to turn the inverter on. The maximum current in this connection is under 0.1 ADC, and has a maximum open circuit voltage of either 24, 48, or 108 VDC. An appropriately rated switch should be used. The remote switch and front panel switch are "OR'd" together so if either switch is on, the inverter system will turn on, and both must be off for shut down. When using the remote switch, insure the front panel switch is in the "OFF" position to control the inverter system with the remote switch.

## **Over Voltage Protection:**

The inverter system will shutdown immediately if the DC voltage exceeds the set limits. When the voltage returns to the normal range, the inverter system will immediately restart. There is a small amount of hysteresis built into the over voltage turn off set point to avoid the possibility of turning off and on rapidly. An over voltage greater than 10% above the limit may cause damage.

## **Under Voltage Protection:**

The inverter system will shutdown when the DC voltage goes below the set limit. The inverter system monitoring module will set an alarm when the inverter system reaches a voltage 5% above the low voltage set limit. When the voltage rises to approximately 15% above the low voltage set limit, the inverter system will turn back on and the alarm condition will clear.

## **Power Modules**

### **DC Voltage Inputs:**

24V, 48V, and 108V DC inputs are available. It is recommended to have a maximum ripple voltage of less than 5% with the peaks not going above  $V_{max}$  and below  $V_{min}$ .

### **AC Voltage Outputs:**

120V, 277V, 230V AC outputs are available (+/- 6%) at 50Hz, 60Hz, and 400Hz (+/- 0.1%).

### **Load Sharing:**

By control system design, the power modules will automatically load share current with other power modules. The load sharing occurs immediately when a module is either added or removed from a power module cage assembly. If a module fails for any reason, the remaining modules will immediately redistribute the load among themselves.

### **Cooling:**

A microprocessor controlled variable speed fan is located on the face plate of the power module. The fan will operate when the module senses an appropriate combination of temperature and power. Fan speed is monitored, and reported to the inverter system monitoring module. Fan speed can be displayed on the power module's LCD display.

### **Over Temperature Protection:**

Each power module will go into thermal shutdown when its internal temperature exceeds the maximum set point. Approximately 5C prior to thermal shutdown, a warning alarm will be sent to the inverter system monitoring module, and will also be displayed on the power module's LCD display. The power module will provide its full rated output up to the temperature listed in the specification sheet. Ambient temperatures in excess of the maximum specification will likely result in thermal shutdown unless the load is reduced appropriately (see detailed specifications for derating). When the power module shuts down, the alarm condition will persist and the cooling fans will continue to run. The power module will automatically restart when it has sufficiently cooled.

# LC SERIES SYSTEM OVERVIEW

## **Overload/Short Circuit Protection:**

If the load attempts to draw current in excess of this value, the output waveform will be “clipped” so that this limit is never exceeded.

The power module has a continuous output of 2000 Watts. In addition, the power module is also able to provide a 3 second surge of up to 4000 Watts (depending on the battery voltage and internal temperature). This surge current is available to supply the inrush current demanded by electronic or motor loads. If the surge persists for longer than 3 seconds, the waveform will be “clipped” in an attempt to reduce the output to under 2000 Watts. If “clipping” the waveform is ineffective in reducing the output below 2000 Watts (as would be the situation for an overload/short circuit condition), the power module will shut down after a period of about 7 seconds. Once shut down, it requires cycling the inverter system's ON/OFF switch to reset from this condition. The cause of the overload/short circuit condition must be removed prior to cycling the ON/OFF switch, otherwise, the inverter system will shut down again after the 7 second delay.

## **2.3 Monitoring Module**

### **Alarm Card:**

#### **Alarm LEDs:**

The alarm card will monitor and display different alarms from the system through the LED's on the front panel.

#### **On/Off Switch:**

The on/off switch is located on the front plate of the alarm card. It is used to turn the inverter system on and off.

#### **Relay Contacts for Alarms:**

Dry relay contacts are available on the backplane to be used with pre set alarms (Alarm1/Minor & Alarm 2/Major).

### **Monitor Card:**

#### **Alarm LEDs:**

The monitor card will monitor and display different alarms from the system through the LED's on the front panel.

#### **On/Off Switch:**

The on/off switch is located on the front plate of the monitor card. It is used to turn the inverter system on and off.

#### **Relay Contacts for Alarms:**

Dry relay contacts are available on the backplane to be used with programmable alarms (Alarm1/Minor & Alarm 2/Major).

### **Ethernet Monitoring:**

An Ethernet port is available on the front panel to connect to a network for remote monitoring of the system. This includes the industry standard Modbus over Ethernet or SNMPv2 remote monitoring or an optional secure SNMPv3 connection.

# LC SERIES POWER INVERTER SPECIFICATIONS

## INPUT POWER (PER EACH POWER MODULE)

MODEL VOLTAGE	MINIMUM (TYPICAL)	SYSTEM (TYPICAL)	MAXIMUM (TYPICAL)	TYPICAL EFFICIENCY @ FULL POWER	PEAK EFFICIENCY @ 1/2 POWER
24V	20.8V	27.6V	30V	> 88%	> 91%
48V	41.6V	55.2V	60V	> 88%	> 91%
108V	93.6V	124.2V	135V	> 88%	> 91%

## PROTECTION CIRCUITRY

Over Voltage:	Shutoff at maximum input voltage, per input table.
Under Voltage:	Shutoff at minimum input voltage, per input table.
Thermal:	Shuts off due to over temperature condition.
Output Short:	Unit shuts off: electronically limited. Manual reset required.

## OUTPUT POWER (PER EACH POWER MODULE)

CONTINUOUS POWER	SURGE POWER (3 seconds)	NO LOAD POWER	OUTPUT VOLTAGE	OUTPUT CURRENT	WEIGHT LBS.
2000W	4000W	15W	120V +/-2%	16.7 A	9
2000W	4000W	15W	277V +/-2%	7.2 A	9
2000W	4000W	15W	230V +/-2%	8.7 A	9

## ENVIRONMENTAL

Temperature:	-25°C to +40°C full power, derated -25% per 10°C above 40°C.
Humidity:	5 to 95% non-condensing
Altitude:	-60m to 3,048m (-197ft. To 10,000ft.) Altitudes >10,000ft. thermally derate from 40°C to 30°C.
Cooling:	Thermostatically controlled variable speed forced air.
Warranty:	Full year parts and labor.

## GENERAL

CONDITIONS	MINIMUM	TYPICAL	MAXIMUM
WAVEFORM	-	SINUSOIDAL	-
LINE REGULATION	-	.1%	2%
LOAD REGULATION	-	1%	2%
DISTORTION	-	1.5%	2%
FREQUENCY	-1%	60Hz	+1%

## PHYSICAL SPECIFICATIONS

**Dimensions:** 8.65" x 3.2" x 16.25" (H x W x D)

**Weight:** 9lbs

## Monitoring Module Electrical Specifications

### Electrical Specifications

<b>Inverter Voltage Reading:</b>	True RMS Voltage +/- 1%
<b>Inverter Current Reading:</b>	True RMS Current +/- 1%
<b>Frequency Reading:</b>	1/10 Hz resolution
<b>DC Voltage Reading:</b>	Nominal DC Voltage +/- 1%

### Physical Specifications

**Dimensions:** 8.65" x 3.2" x 16.25" (H x W x D)

**Weight:** < 1.5 lbs



# LC SERIES 12KW SYSTEM SPECIFICATIONS

## INPUT POWER

MODEL VOLTAGE	MINIMUM (TYPICAL)	SYSTEM (TYPICAL)	MAXIMUM (TYPICAL)	MAXIMUM CURRENT
24V	20.8V	27.6V	30V	700A
48V	41.6V	55.2V	60V	350A
108V	93.6V	124.2V	135V	160A

## OUTPUT POWER

CONTINUOUS POWER	SURGE POWER (3 seconds)	OUTPUT VOLTAGE	OUTPUT CURRENT	WEIGHT LBS. (With Monitoring Module)
12000W	24000W	120V +/-2%	100 A	69
12000W	24000W	277V +/-2%	43.3 A	69
12000W	24000W	230V +/-2%	52.2 A	69

## GENERAL

CONDITIONS	MINIMUM	TYPICAL	MAXIMUM
WAVEFORM	-	SINUSOIDAL	-
LINE REGULATION	-	.1%	2%
LOAD REGULATION	-	1%	2%
DISTORTION	-	1.5%	2%
FREQUENCY	-.1%	60Hz	+.1%

## PHYSICAL SPECIFICATIONS

**Dimensions:** 8.75" x 21" x 20" (H x W x D)  
8.75" x 23" x 20" (H x W x D) (Includes rack/shelf mounting hardware)

**Mounting Clearance Requirements** Above: 1.75" (1 U)  
Front: 18"  
Rear: 18"

**Access:** Rear for Installation and Maintenance and Front for Operation

**Control:** Microprocessor control, Ethernet based monitoring

**Options:** Pre-charge Circuit Panel PN: 800-DCPRE-400

**Accessories:** Blank Position Cover Panel PN: 020-00411-400  
Relay Rack Mounting Bracket PN: 020-00317-401  
Surface Mounting Bracket PN: 020-00222-400

# LC SYSTEMS POWER MODULE

## **DC Voltage Inputs:**

24V, 48V, and 108 VDC inputs are available. It is recommended to have a maximum ripple voltage of less than 5% with the peaks not going above  $V_{max}$  and below  $V_{min}$ .

## **AC Voltage Outputs:**

120V, 277V and 230V AC outputs are available (+/- 6%) at 50Hz, 60Hz and 400Hz (+/- 0.1%).

## **Load Sharing:**

By control system design, the power modules will automatically load share current with other power modules. The load sharing occurs immediately when a module is either added or removed from a power module cage assembly. If a module fails for any reason, the remaining modules will immediately redistribute the load among themselves.

## **Cooling:**

A microprocessor controlled variable speed fan is located on the face plate of the power module. The fan will operate when the module senses an appropriate combination of temperature and power. Fan speed is monitored, and reported to the inverter system monitoring module. Fan speed can be displayed on the power module's LCD display.

## **Over Temperature Protection:**

Each power module will go into thermal shutdown when its internal temperature exceeds the maximum set point. Approximately 5C prior to thermal shutdown, a warning alarm will be sent to the inverter system monitoring module, and will also be displayed on the power module's LCD display. The power module will provide its full rated output up to the temperature listed in the specification sheet. Ambient temperatures in excess of the maximum specification will likely result in thermal shutdown unless the load is reduced appropriately (see detailed specifications for derating). When the power module shuts down, the alarm condition will persist and the cooling fans will continue to run. The power module will automatically restart when it has sufficiently cooled.

## **Overload/Short Circuit Protection:**

If the load attempts to draw current in excess of this value, the output waveform will be "clipped" so that this limit is never exceeded.

The power module has a continuous output of 2000 Watts. In addition, the power module is also able to provide a 3 second surge of up to 4000 Watts (depending on the battery voltage and internal temperature). This surge current is available to supply the inrush current demanded by electronic or motor loads. If the surge persists for longer than 3 seconds, the waveform will be "clipped" in an attempt to reduce the output to under 2000 Watts. If "clipping" the waveform is ineffective in reducing the output below 2000 Watts (as would be the situation for an overload/short circuit condition), the power module will shut down after a period of about 7 seconds. Once shut down, it requires cycling the inverter system's ON/OFF switch to reset from this condition. The cause of the overload/short circuit condition must be removed prior to cycling the ON/OFF switch, otherwise, the



# LC SYSTEMS ALARM CARD

The alarm card can be added to 19" and 23" power module cages.

The alarm card is powered by the inverter or utility.

Each alarm card is specific to one input voltage.

AC & DC alarms only (Non-Programmable)

No data reporting through Ethernet.

Data can be monitored via power module LCD display.

## **Faceplate Displays:**

### **INVERTER SWITCH:**

Up is "ON" and Down is "OFF"

### **PHASE TEST BUTTONS:**

Test the following functions for each phase:

- AC ALARMS
- AC LED STATUS
- MASTER TOGGLE

### **PHASE STATUS LED:**

Will be green when AC power is in specs

### **DC STATUS LED:**

Will be green when the DC power is in specs

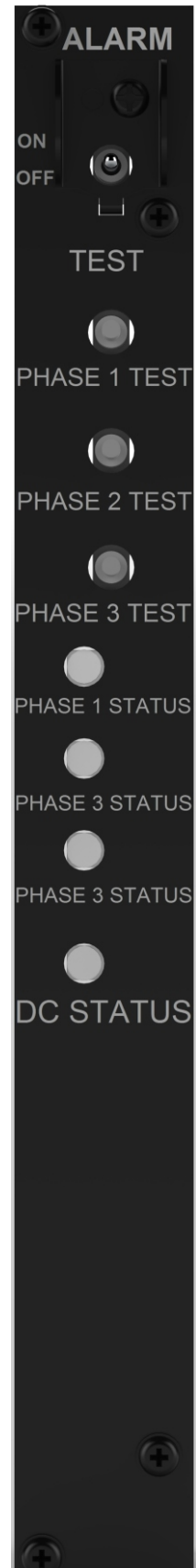

# LC SYSTEMS MONITOR CARD

It is now possible to monitor all of your remote power stations from a single location. You can have up to the minute verification that all of your remote power systems are 100% operational. For example, the remote power system can report that it is currently running at 90% of its rated capacity.

## **Operation**

Normal operation of the monitor card is similar to the alarm card previously described in this document. The biggest difference is the remote monitoring of the system data.

## **Remote Monitoring**

Ethernet connection allows for remote monitoring of system data. Each phase's information can be reported via an Ethernet connection. The data can be sent to a PC to be viewed and logged or reported via SNMPv2 or an optional secure SNMPv3. Programmable Alarm 1/Minor and Alarm 2/Major are provided via dry form C relay contacts. Use of the other alarm ports on the back plane may result in damage to the module or system.

## **Differences from Alarm Card:**

- Remote data monitoring
- Not limited to a specific input voltage
- Allows for programmable alarms
- Built in microprocessor that allows for a wider range of system data. Data can be monitored both remotely and via power module LCD display.

## **Faceplate Displays:**

### **INVERTER SWITCH:**

Up is "ON" and down is "OFF"

### **PHASE STATUS LED:**

Will be green when AC power is in specs

### **COMM STATUS:**

Will be green when monitor card is communicating to another device.

### **IP RESET:**

When pushed it will Reboot the communication port

### **Ethernet Port:**

Allows connection to the inverter system via Ethernet cable

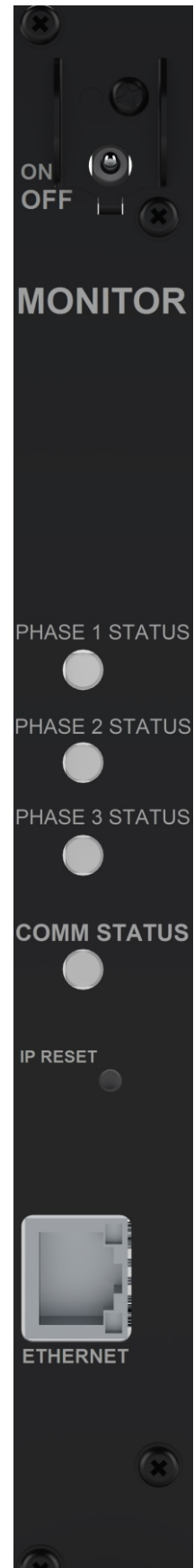

# LC SERIES PART NUMBERING SYSTEM

## LC SERIES SYSTEM PART NUMBER

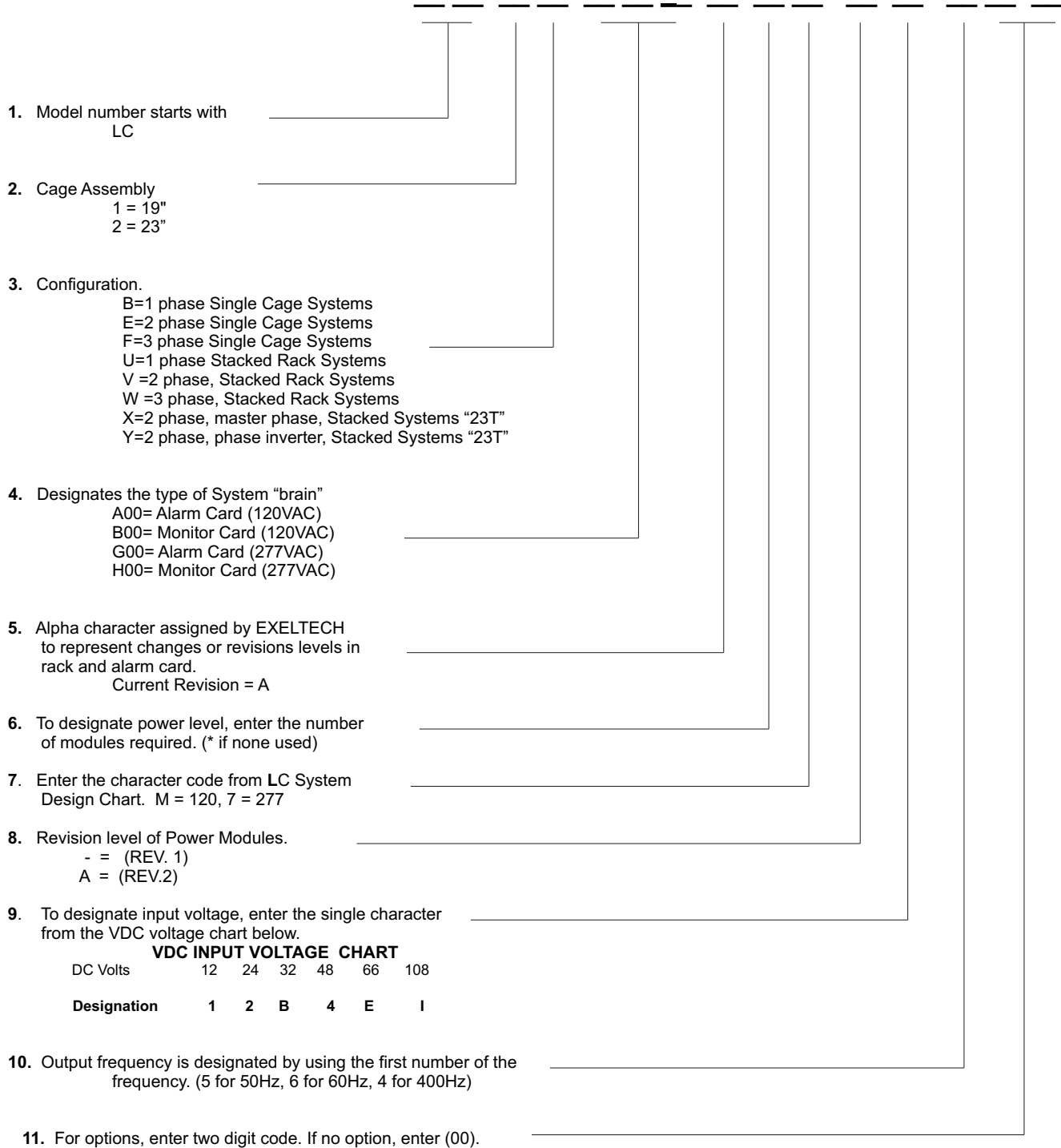

## STATIC TRANSFER SWITCH SYSTEM



- **SOLID STATE SCR-BASED SWITCHING**
- **ZERO TRANSFER TIME**
- **DETECTION TIME < 4MSEC**
- **LED ALARMS**
- **PROGRAMMABLE ALARMS**
- **REMOTE MONITORING**
- **PRIMARY SOURCE SWITCH**

Exeltech's Static Transfer Switch Systems install into either a 19" or 23" Exeltech 4RU cage. This STS system is specifically designed to be installed with Exeltech MX or LC inverter systems to allow a secondary source of AC power. The system can be configured for 1, 2, or 3 phases with each phase capable of either 85 or 170 Amps.

The STS system will maintain continuous AC output in the event of a single AC source failure. Detecting a failure and transferring to the secondary source is typically under 4ms. Most loads will not be disturbed with a single source failure.

Components in the STS system vary with different power levels, voltage levels, and number of phases. All STS systems are equipped with AC source monitoring via SNMP & Modbus over TCP/IP.

Exeltech recommends STS systems be used with a Maintenance bypass switch.



# STS System Modules Overview

## STS Backplane and Relay Assembly

STS backplane & relay assembly is a common component among all STS systems. The backfeed relay is a safety mechanism to prevent backfeed onto the utility AC source in the event of multiple component failures. The backplane assembly is used to complete power and signal paths between STS Controller, STS Powerswitch(s), and the backfeed relay. The backplane also provides the power output connections, alternate source input connections, and dry contact alarm connections.

## STS Powerswitch Module

The STS Powerswitch module contains the SCR and cooling components required to continuously supply high current to the load from either source. Each phase requires a dedicated STS Powerswitch. So a 3 phase system would require 3 STS Powerswitch modules. The STS Powerswitch is available in 85A and 170A models for different power needs. Each installation will require external overcurrent protection to ensure the STS Powerswitch does not operate above the rated current. Each STS Powerswitch contains LED indicators showing the status of inverter source, utility source, and output. The STS Controller is responsible for operation of the SCR components in the STS Powerswitch.

## STS Controller Module

The STS Controller module is a microprocessor based PCB that monitors the AC sources and controls the operation and automatic transfer of the STS Powerswitch modules. A toggle switch on the STS Controller is used to set the primary source for the output power. The STS Controller determines the state of each source as good, bad, or failed and will automatically switch from a bad or failed source to a good source. Total detect and transfer time for a failed source is typically 4ms.

The STS Controller has three LEDs to indicate the status of each phase and one to indicate the overall status of the STS system. LED indicator descriptions can be found in the Section 4.2 of this manual. All of the system data can be accessed through the ethernet port on the STS Controller. The data is available via SNMP & Modbus.

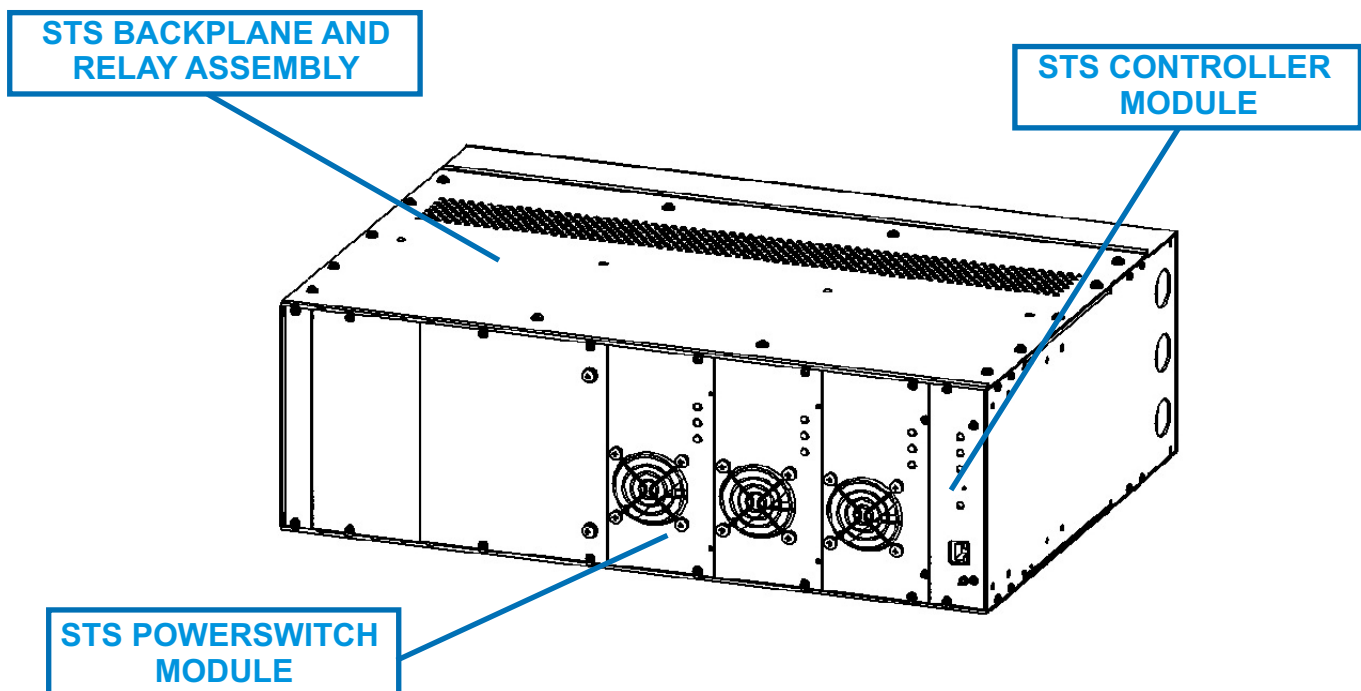

# Standard Features

## **System Configuration**

The system can be configured for 1, 2, or 3 phases with each phase capable of either 85 or 170 Amps. The STS system is available in 19 inch and 23 inch 4RU cages. Exeltech recommends a maintenance bypass switch (MBS) be installed with all STS systems.

### **MBS Lockout:**

A set of terminals are provided to connect the auxiliary signal wires from an Exeltech MBS to the STS system. This signal alerts the STS Controller that the MBS is about to activate. The STS Controller then forces the STS Powerswitch to utility source for a safe make-before-break actuation of the MBS into the bypass position.

### **Dry Contact Alarms:**

The STS system has 3 sets of dry contact relay alarms. The output alarm is on the STS Powerswitch and two programmable alarms are controlled by the STS Controller. Alarm connections are located on the backplane.

### **Remote Monitoring Software:**

Product Status is a light weight Java based GUI developed by Exeltech and available on Exeltech's website. The monitoring window is a simple method to view the status of various system parameters. It can also be used to change alarm configurations and for event data logging. The STS controller communicates to Product Status using Modbus over ethernet. The IP address can be assigned by DHCP or static IP.

STS controller can communicate with third party software through SNMP protocol or Modbus over ethernet. The .mib file for SNMP monitoring is available on Exeltech's website.

### **Transfer time:**

All SCR based transfer switches are constrained to transfer at a current zero cross. Good to good transfers are seamless because they are timed to occur at the zero cross of the current waveform. Transfer time can vary from zero to up to 4 ms for failed source transfers depending upon where in the waveform the failure is detected.

# STS Controller Module

## Description:

### LED Phase Indicators:

- Blinking Green - MBS Active
- Solid Green - Both Sources Good
- Solid Orange - Secondary Source Bad or Failed
- Blinking Orange - Primary Source Bad or Failed
- (Primary/Secondary Sources are indicated by the primary select switch)

### LED Status Indicator:

- Blinking Orange - Startup, acquiring Address/TCP connection
- Blinking Green - Startup complete, Modbus communication underway.
- Blinking Red/Green – Backfeed prevention active
- Solid Red – System Fault

### Relay Contacts for Alarms:

Two programmable dry contact relays are available on the backplane.

### Monitoring:

Modbus TCP/ IP and SNMP over Ethernet included to monitor all system information and provides traps to indicate service requests.

### Primary select:

A toggle switch on the face plate sets the STS System to run from either inverter primary or utility primary.

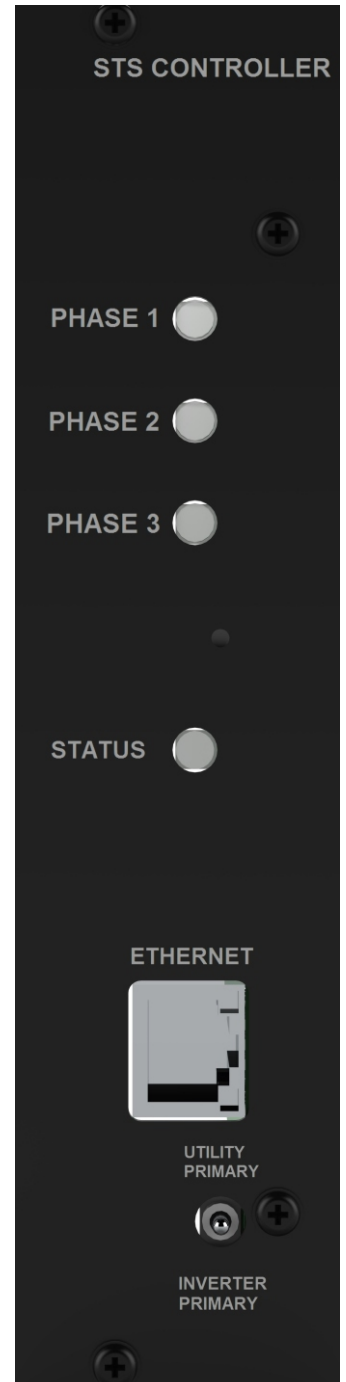

# STS Powerswitch Module

## Components:

The STS powerswitch design contains minimal components thus reducing the opportunity for component defects and failures. This minimal approach is achieved by locating the controls and microprocessors on the STS controller.

## LED Indicators:

On – Output energized  
Utility – Utility energized  
Inverter – Inverter energized

## Cooling:

A controlled variable speed fan is located on the face plate of the STS powerswitch. The fan will operate when the module senses an appropriate temperature. Fan speed and SCR temperature are monitored, and reported to the STS controller.

## Over Temperature Protection:

Each STS powerswitch will go into thermal shutdown when the heatsink temperature exceeds the maximum set point. Approximately 5C prior to thermal shutdown, a warning alarm will be sent from the STS controller module, ambient temperatures in excess of the maximum specification could result in thermal shutdown unless the load is reduced appropriately. During thermal overload, the STS powerswitch will shut down and the alarm condition will persist. The module will automatically restart when it has sufficiently cooled.

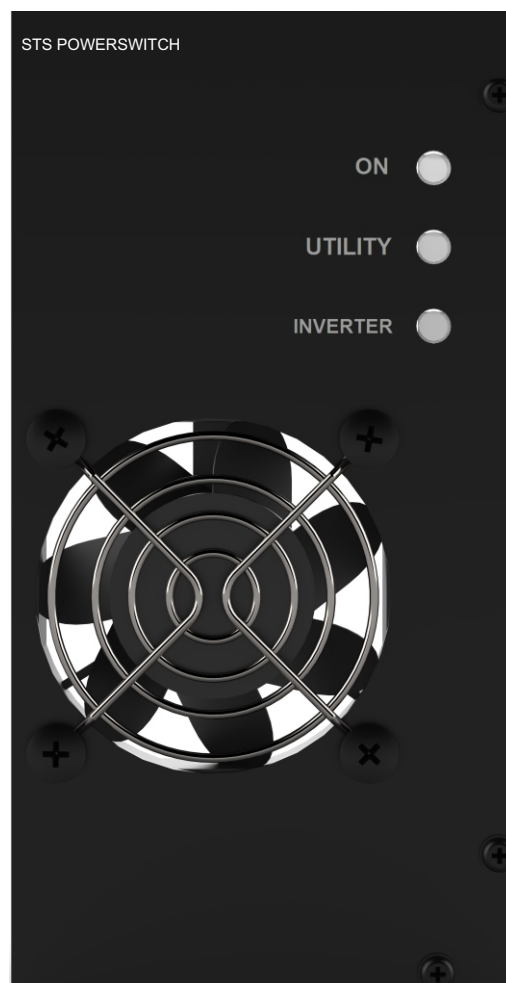

# STS System Specifications

## INPUT POWER

INPUT VOLTAGE	INPUT FREQUENCY
90 - 135 VAC	58 - 61 Hz

## OUTPUT POWER

OUTPUT VOLTAGE	TRANSFER TIME (TYPICAL FOR DETECT AND TRANSFER)
Same as utility voltage or inverter voltage	4ms

## PROTECTION CIRCUITRY

Over Voltage:	Shutoff at maximum input voltage, per input table.
Under Voltage:	Shutoff at minimum input voltage, per input table.
Thermal:	Shuts off due to over temperature condition.
Output Short:	Unit shuts off: electronically limited. Manual reset required.

## ENVIRONMENTAL

Temperature:	-25°C to +40°C full power, derated -20% per 10°C above 40°C.
Humidity:	5 to 95% non-condensing
Altitude:	-60m to 1800m (-197ft. To 5906ft.)
Cooling:	Thermostatically controlled variable speed forced air.
Warranty:	Full year parts and labor.

## Output Capacity (per phase)

STS POWERSWITCH MODEL	MAX WATTS	OUTPUT VOLTAGE	OUTPUT CURRENT	OPERATING TEMP. (C)
10kW	10,000W	117V	85 Amps	40C
20kW	20,000W	117V	170 Amps	40C

## PHYSICAL SPECIFICATIONS

<b>Framework Type:</b> Exeltech 4RU Cage			
<b>Dimensions:</b> 7" x 17.2" x 15" (H x W x D) for 19" Relay Rack 7" x 21.2" x 15" (H x W x D) for 23" Relay Rack			
<b>Mounting Clearance Requirements</b> Above: 1.75" (1 U) Front: 12" Rear: 18"			
<b>Weight:</b>	<u>Weight:</u>	<u>85 Amp</u>	<u>170 Amp</u>
	1 Phase	20.5 lbs	22.5 lbs
	2 Phase	23.0 lbs	27.0 lbs
	3 Phase	25.5 lbs	31.5 lbs
<b>Access:</b>	Rear for Installation and Maintenance and Front for Operation		
<b>Control:</b>	Microprocessor control, Ethernet based monitoring		
<b>Options:</b>	Maintenance Bypass Switch (Recommended)		
<b>AC Connection points:</b>			
Mechanical Lugs: 1/0 – 6 AWG			
Recommended Torque: 45 in-lbs.			
Customer Interface: 250MCM available in systems with AC customer interface			

# STS Module Specifications

## STS Powerswitch Module Electrical Specifications

OUTPUT CURRENT AMPS AC	SCR VOLTAGE DROP (TYPICAL)	FAN TURN ON TEMP C	FAN FULL SPEED TEMP C	THERMAL SHUTDOWN TEMP C	THERMAL RECOVERY TEMP C	CONTINUOUS CURRENT RATING	FORM C RELAY ALARM 250VAC/VDC
85A	1.3V	50C	65C	75C	70C	85V	1.5A
170A	1.3V	45C	60C	70C	65C	170A	1.5A

## Physical Specifications

<b>Dimensions:</b> 6.8" x 3.2" x 12.3" (H x W x D)
<b>Weight:</b> 2.5 lbs (85A) / 4.5 lbs (170A)

## STS Powerswitch Heat Dissipation Table:

Output Current Amps AC	Output Power @ 117 VAC	V drop Across SCR	Power Loss Watts	Input Power Watts AC	Efficiency (%)	Heat Dissipation BTU/Hr
<b>170 Amp</b>						
50	5850	1.3	65.0	5915	98.90	222
100	11700	1.3	130.0	11830	98.90	444
150	17550	1.3	195.0	17745	98.90	666
170	19890	1.3	221.0	20111	98.90	755
<b>85 Amp</b>						
25	2925	1.3	32.5	2958	98.90	111
50	5850	1.3	65.0	5915	98.90	222
75	8775	1.3	97.5	8873	98.90	333
85	9945	1.3	110.5	10056	98.90	377

## STS Controller Module Electrical Specifications

INPUT VOLTAGE	INPUT FREQUENCY
90 - 135 VAC	58 - 61 Hz

## Physical Specifications

<b>Dimensions:</b> 6.8" x 1.6" x 12.3" (H x W x D)
<b>Weight:</b> 0.8 lbs



# STATIC TRANSFER SWITCH ASSEMBLY Part Numbering System

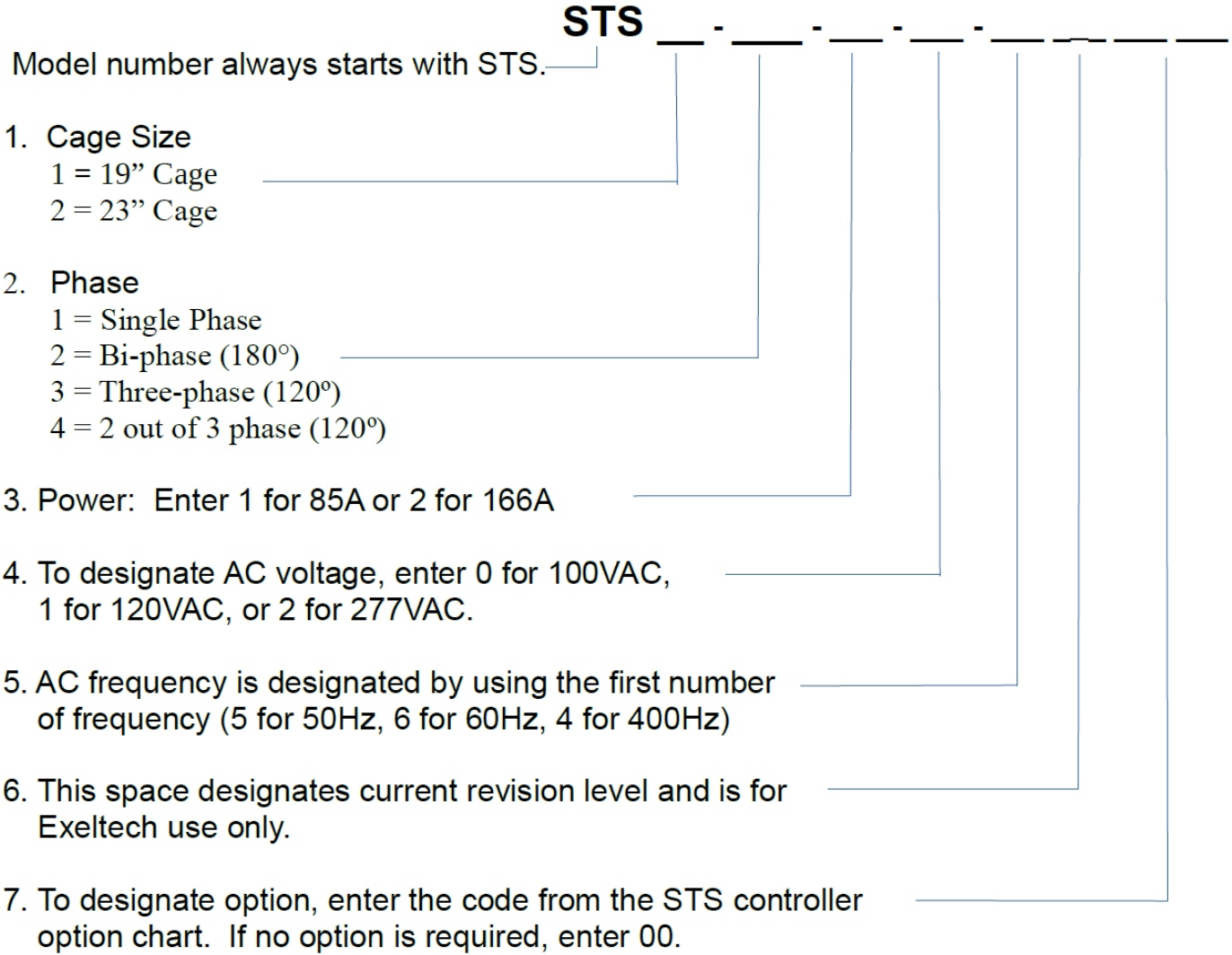

Example: 19" Three phase 20kW 120VAC 60Hz – STS1-3-2-1-6100

Manufacturer of True Sine Wave Power Inverters and Related Products

## NC SERIES POWER INVERTER



**NEBS  
LEVEL 3  
CERTIFIED**

Exceeding Expectations for your Protection

- **N+1 REDUNDANT**
- **EXPANDABLE**
- **REMOTE SWITCHING**
- **TRUE SINE WAVE**
- **“HOT” INSERTABLE**
- **2000 WATT MODULES**
- **OPTIONAL SNMP**

Exeltech's NC Series Telecommunication Inverter Systems are engineered to address the high reliability and safety demands of the telecommunication industry.

NC series inverter systems are equipped with 2KW power modules. Modules are "hot" insertable, power levels are expandable, and modules can be added or replaced without interruption in power to your critical loads.

The NC system can be configured for power levels from 2 to 36KW single phase with 120Vac output. Up to 18KW per phase at 240Vac bi-phase or 12KW per phase at 208Vac three-phase with 48v inputs available.

A monitoring module plus any number of additional 2KW power modules combine to make a standard NC inverter. This type of system can be expanded as power requirements increase, and upgraded to be N+1 redundant as desired.

The NC system is extremely compact and lightweight. Power modules weigh only 9 lbs each and are equipped with LCD screens for quick access of system data.

Output voltage is precisely regulated, so that no measurable voltage change occurs on the output as input voltage fluctuates. Similarly, less than 0.5 volt change in output voltage will occur when the output load varies from 0 to 100% of rated power. With distortion of 2% maximum, this inverter offers the cleanest sine wave power available.

# NC SERIES MODULE OVERVIEW

## 1.2 Modules Overview

The NC Series inverters are a modular design and allows each system to be tailored for specific needs. Systems can range in output power, redundancy, and a variety of other options. This is done by selecting different combinations of modules to create a NC telecommunication inverter system.

### 1.2.1 Power Module Cage Assembly

The cage assembly can be designed to accept DC input of either positive or negative. It will house from 1 to 6 inverter power modules resulting in a system output of up to 12,000 Watts. It will also house an optional monitoring module (recommended). The left most power module is the system's master module. The next power module to the right is the system's redundant (backup) master module. For redundant operation the system MUST include a monitoring module. The monitoring module is required to initiate a transfer of control to the backup master module.

### 1.2.2 Power Modules

The power module is the backbone of the NC telecommunications inverter system and is the majority of the modules in all systems. Each module is capable of producing 2000 Watts of continuous output power. Each module can perform all of the functions to operate as a system's master module. The module will only perform the system master function when placed in the power module cage assembly location identified in the previous section. Each power module is equipped with an LCD display that can show power module status information as well as system status information.

### 1.2.3 Monitoring Module

The monitoring module provides a visual representation of different alarms created by the system. Each monitoring module has an ON/OFF switch for the system. If a monitoring module is not used the remote switch must be used to turn the system on and off. A monitoring module is required to detect a master power module failure and switch to the secondary master power module if it is available. There are a few different options available to monitor the NC inverter system.

#### 1. Alarm Card:

With the alarm card, system monitoring is basic and is seen manually through power module LCD displays. Pre set alarms (Alarm 1/Minor & Alarm 2/Major) are provided via dry form C relay contacts on the inverter systems backplane. Use of the other connections on the back plane may result in damage to the module or system.

#### 2. Monitor Card:

With the monitor card, system data is more detailed and can be seen either manually through power module LCD displays or through Ethernet connection which allows for remote monitoring of system data. Each phase's information can be reported via the Ethernet connection. The data can be sent to a PC to be viewed and logged or reported via SNMPv2 or an optional secure SNMPv3. Programmable alarms (Alarm 1/Minor & Alarm 2/Major) are provided via dry form C relay contacts on the inverter systems backplane. Product Status is used to program alarms. Use of the other connections on the back plane may result in damage to the module or system.

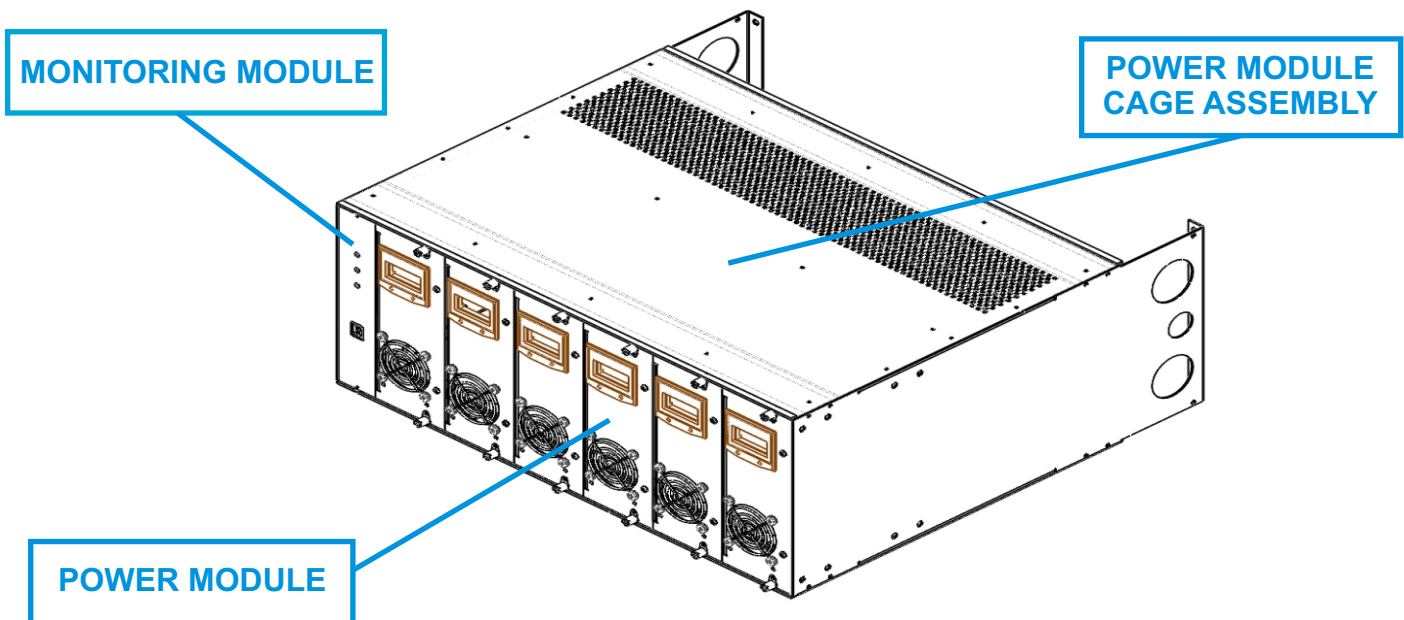

# NC SERIES SYSTEM OVERVIEW

The NC system can be configured from 2,000 to 12,000 Watts (1 to 6 power modules), with or without an optional monitoring module (highly recommended). With the monitoring module and a sufficient number of power modules, the system provides N+1 redundancy.

## **Remote On/Off Switch:**

A set of terminals are provided to turn the inverter system on and off from a remote location. The connection for the remote switch is on a remote alarm connector located under the rear access cover. Connect battery negative 'Bat(-)' to the 'Sw1' terminal to turn the inverter on. The maximum current in this connection is under 0.1 ADC, and has a maximum open circuit voltage of 48VDC. An appropriately rated switch should be used. The remote switch and front panel switch are "OR'd" together so if either switch is on, the inverter system will turn on, and both must be off for shut down. When using the remote switch, insure the front panel switch is in the "OFF" position to control the inverter system with the remote switch.

## **Over Voltage Protection:**

The inverter system will shutdown immediately if the DC voltage exceeds the set limits. When the voltage returns to the normal range, the inverter system will immediately restart. There is a small amount of hysteresis built into the over voltage turn off set point to avoid the possibility of turning off and on rapidly. An over voltage greater than 10% above the limit may cause damage.

## **Under Voltage Protection:**

The inverter system will shutdown when the DC voltage goes below the set limit. The inverter system monitoring module will set an alarm when the inverter system reaches a voltage 5% above the low voltage set limit. When the voltage rises to approximately 15% above the low voltage set limit, the inverter system will turn back on and the alarm condition will clear.

## **Power Modules**

### **DC Voltage Inputs:**

48VDC inputs are available. It is recommended to have a maximum ripple voltage of less than 5% with the peaks not going above  $V_{max}$  and below  $V_{min}$ .

### **AC Voltage Outputs:**

120V outputs are available (+/- 5%) at 60Hz, (+/- 0.1%).

### **Load Sharing:**

By control system design, the power modules will automatically load share current with other power modules. The load sharing occurs immediately when a module is either added or removed from a power module cage assembly. If a module fails for any reason, the remaining modules will immediately redistribute the load among themselves.

### **Cooling:**

A microprocessor controlled variable speed fan is located on the face plate of the power module. The fan will operate when the module senses an appropriate combination of temperature and power. Fan speed is monitored, and reported to the inverter system monitoring module. Fan speed can be displayed on the power module's LCD display.

### **Over Temperature Protection:**

Each power module will go into thermal shutdown when its internal temperature exceeds the maximum set point. Approximately 5C prior to thermal shutdown, a warning alarm will be sent to the inverter system monitoring module, and will also be displayed on the power module's LCD display. The power module will provide its full rated output up to the temperature listed in the specification sheet. Ambient temperatures in excess of the maximum specification will likely result in thermal shutdown unless the load is reduced appropriately (see detailed specifications for derating). When the power module shuts down, the alarm condition will persist and the cooling fans will continue to run. The power module will automatically restart when it has sufficiently cooled.

# NC SERIES SYSTEM OVERVIEW

## **Overload/Short Circuit Protection:**

If the load attempts to draw current in excess of this value, the output waveform will be “clipped” so that this limit is never exceeded.

The power module has a continuous output of 2000 Watts. In addition, the power module is also able to provide a 3 second surge of up to 4000 Watts (depending on the battery voltage and internal temperature). This surge current is available to supply the inrush current demanded by electronic or motor loads. If the surge persists for longer than 3 seconds, the waveform will be “clipped” in an attempt to reduce the output to under 2000 Watts. If “clipping” the waveform is ineffective in reducing the output below 2000 Watts (as would be the situation for an overload/short circuit condition), the power module will shut down after a period of about 7 seconds. Once shut down, it requires cycling the inverter system's ON/OFF switch to reset from this condition. The cause of the overload/short circuit condition must be removed prior to cycling the ON/OFF switch, otherwise, the inverter system will shut down again after the 7 second delay.

## **Monitoring Module**

### **Alarm Card:**

#### **Alarm LEDs:**

The alarm card will monitor and display different alarms from the system through the LED's on the front panel.

#### **On/Off Switch:**

The on/off switch is located on the front plate of the alarm card. It is used to turn the inverter system on and off.

#### **Relay Contacts for Alarms:**

Dry relay contacts are available on the backplane to be used with pre set alarms (Alarm 1/Minor & Alarm 2/Major).

### **Monitor Card:**

#### **Alarm LEDs:**

The monitor card will monitor and display different alarms from the system through the LED's on the front panel.

#### **On/Off Switch:**

The on/off switch is located on the front plate of the monitor card. It is used to turn the inverter system on and off.

#### **Relay Contacts for Alarms:**

Dry relay contacts are available on the backplane to be used with programmable alarms (Alarm 1/Minor & Alarm 2/Major).

### **Ethernet Monitoring:**

An Ethernet port is available on the front panel to connect to a network for remote monitoring of the system. This includes the industry standard Modbus over Ethernet or SNMPv2 remote monitoring or an optional secure SNMPv3 connection.



# NC SERIES POWER INVERTER SPECIFICATIONS

## INPUT POWER (PER EACH POWER MODULE)

MODEL VOLTAGE	MINIMUM (TYPICAL)	SYSTEM (TYPICAL)	MAXIMUM (TYPICAL)	TYPICAL EFFICIENCY @ FULL POWER	PEAK EFFICIENCY @ 1/2 POWER
48V	40V	53V	60V	> 88%	> 91%

## OUTPUT POWER (PER EACH POWER MODULE)

CONTINUOUS POWER	SURGE POWER (3 seconds)	NO LOAD POWER	OUTPUT VOLTAGE	OUTPUT CURRENT	WEIGHT LBS.
2000W	4000W	15W	120V+/-2%	16.7 A	9

## PROTECTION CIRCUITRY

Over Voltage:	Shutoff at maximum input voltage, per input table.
Under Voltage:	Shutoff at minimum input voltage, per input table.
Thermal:	Shuts off due to over temperature condition.
Output Short:	Unit shuts off: electronically limited. Manual reset required.

## GENERAL

CONDITIONS	MINIMUM	TYPICAL	MAXIMUM
WAVEFORM	-	SINUSOIDAL	-
LINE REGULATION	-	.1%	2%
LOAD REGULATION	-	1%	2%
DISTORTION	-	1.5%	2%
FREQUENCY	-.1%	60Hz	+ .1%

## ENVIRONMENTAL

Temperature:	-25°C to +40°C full power, derated -25% per 10°C above 40°C.
Humidity:	5 to 95% non-condensing
Altitude:	-60m to 3,962m (-197ft. To 13,000ft.) Altitudes >13,000ft. thermally derate from 40°C to 30°C.
Cooling:	Thermostatically controlled variable speed forced air.
Warranty:	Full year parts and labor.

## PHYSICAL SPECIFICATIONS

<b>Dimensions:</b>	8.65" x 3.2" x 16.25" (H x W x D)
<b>Weight:</b>	9lbs

## Monitoring Module Electrical Specifications

### Electrical Specifications

<b>Inverter Voltage Reading:</b>	True RMS Voltage +/- 1%
<b>Inverter Current Reading:</b>	True RMS Current +/- 1%
<b>Frequency Reading:</b>	1/10 Hz resolution
<b>DC Voltage Reading:</b>	Nominal DC Voltage +/- 1%

### Physical Specifications

<b>Dimensions:</b>	8.65" x 3.2" x 16.25" (H x W x D)
<b>Weight:</b>	< 1.5 lbs



# NC SERIES 12KW SYSTEM SPECIFICATIONS

## INPUT POWER

MODEL VOLTAGE	MINIMUM (TYPICAL)	SYSTEM (TYPICAL)	MAXIMUM (TYPICAL)	MAXIMUM CURRENT
48V	40V	53V	60V	350A

## OUTPUT POWER

CONTINUOUS POWER	SURGE POWER (3 seconds)	OUTPUT VOLTAGE	OUTPUT CURRENT	WEIGHT LBS. (With Monitoring Module)
12000W	24000W	120V+/-2%	100 A	69

## GENERAL

CONDITIONS	MINIMUM	TYPICAL	MAXIMUM
WAVEFORM	-	SINUSOIDAL	-
LINE REGULATION	-	.1%	2%
LOAD REGULATION	-	1%	2%
DISTORTION	-	1.5%	2%
FREQUENCY	-.1%	60Hz	+.1%

## PHYSICAL SPECIFICATIONS

<b>Dimensions:</b>	8.75" x 21" x 20" (H x W x D) 8.75" x 23" x 20" (H x W x D) (Includes rack/shelf mounting hardware)
<b>Mounting Clearance Requirements</b>	Above: 1.75" (1 U) Front: 18" Rear: 18"
<b>Access:</b>	Rear for Installation and Maintenance and Front for Operation
<b>Control:</b>	Microprocessor control, Ethernet based monitoring
<b>Options:</b>	Pre-charge Circuit Panel PN: 800-DCPRE-400
<b>Accessories:</b>	Blank Position Cover Panel PN: 020-00411-400 Relay Rack Mounting Bracket PN: 020-00317-401 Surface Mounting Bracket PN: 020-00222-400

# NC SYSTEMS POWER MODULE

## **DC Voltage Inputs:**

48VDC inputs are available. It is recommended to have a maximum ripple voltage of less than 5% with the peaks not going above  $V_{max}$  and below  $V_{min}$ .

## **AC Voltage Outputs:**

120V outputs are available (+/- 6%) at 60Hz, (+/- 0.1%).

## **Load Sharing:**

By control system design, the power modules will automatically load share current with other power modules. The load sharing occurs immediately when a module is either added or removed from a power module cage assembly. If a module fails for any reason, the remaining modules will immediately redistribute the load among themselves.

## **Cooling:**

A microprocessor controlled variable speed fan is located on the face plate of the power module. The fan will operate when the module senses an appropriate combination of temperature and power. Fan speed is monitored, and reported to the inverter system monitoring module. Fan speed can be displayed on the power module's LCD display.

## **Over Temperature Protection:**

Each power module will go into thermal shutdown when its internal temperature exceeds the maximum set point. Approximately 5C prior to thermal shutdown, a warning alarm will be sent to the inverter system monitoring module, and will also be displayed on the power module's LCD display. The power module will provide its full rated output up to the temperature listed in the specification sheet. Ambient temperatures in excess of the maximum specification will likely result in thermal shutdown unless the load is reduced appropriately (see detailed specifications for derating). When the power module shuts down, the alarm condition will persist and the cooling fans will continue to run. The power module will automatically restart when it has sufficiently cooled.

## **Overload/Short Circuit Protection:**

If the load attempts to draw current in excess of this value, the output waveform will be "clipped" so that this limit is never exceeded.

The power module has a continuous output of 2000 Watts. In addition, the power module is also able to provide a 3 second surge of up to 4000 Watts (depending on the battery voltage and internal temperature). This surge current is available to supply the inrush current demanded by electronic or motor loads. If the surge persists for longer than 3 seconds, the waveform will be "clipped" in an attempt to reduce the output to under 2000 Watts. If "clipping" the waveform is ineffective in reducing the output below 2000 Watts (as would be the situation for an overload/short circuit condition), the power module will shut down after a period of about 7 seconds. Once shut down, it requires cycling the inverter system's ON/OFF switch to reset from this condition. The cause of the overload/short circuit condition must be removed prior to cycling the ON/OFF switch, otherwise, the inverter system will shut down again after the 7 second delay.



# NC SYSTEMS ALARM CARD

The alarm card can be added to 19" & 23" power module cage assemblies.

The alarm card is powered by the inverter or utility.

AC & DC alarms only (Non-Programmable)

No data reporting through Ethernet.

Data can be monitored via power module LCD display.

## **Faceplate Displays:**

### **INVERTER SWITCH:**

Up is "ON" and Down is "OFF"

### **PHASE TEST BUTTONS:**

Test the following functions for each phase:

- AC ALARMS
- AC LED STATUS
- MASTER TOGGLE

### **PHASE STATUS LED:**

Will be green when AC power is in specs

### **DC STATUS LED:**

Will be green when the DC power is in specs

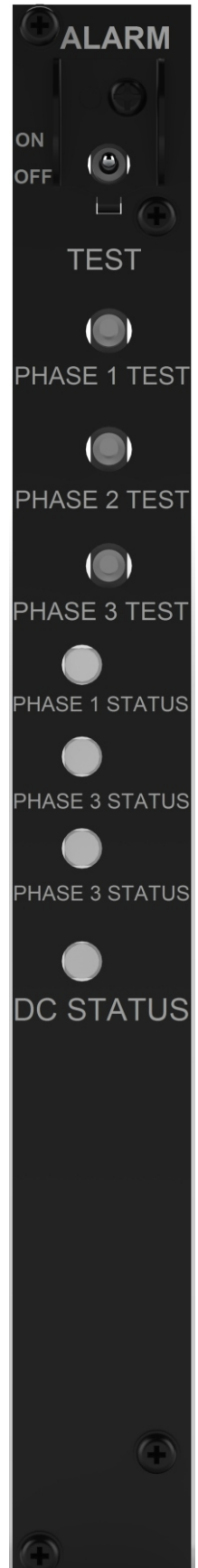

# NC SYSTEMS MONITOR CARD

It is now possible to monitor all of your remote power stations from a single location. You can have up to the minute verification that all of your remote power systems are 100% operational. For example, the remote power system can report that it is currently running at 90% of its rated capacity.

## **Operation**

Normal operation of the monitor card is similar to the alarm card previously described in this document. The biggest difference is the remote monitoring of the system data.

## **Remote Monitoring**

Ethernet connection allows for remote monitoring of system data. Each phase's information can be reported via an Ethernet connection. The data can be sent to a PC to be viewed and logged or reported via SNMPv2 or an optional secure SNMPv3. Programmable alarms (Alarm 1/Minor & Alarm 2/Major) are provided via dry form C relay contacts. Use of the other alarm ports on the back plane may result in damage to the module or system.

## **Differences from Alarm Card:**

- Remote data monitoring
- Allows for programable alarms
- Built in microprocessor that allows for a wider range of system data. Data can be monitored both remotely and via power module LCD display.

## **Faceplate Displays:**

### **INVERTER SWITCH:**

Up is "ON" and down is "OFF"

### **PHASE STATUS LED:**

Will be green when AC power is in specs

### **COMM STATUS:**

Will be green when monitor card is communicating to another device.

### **IP RESET:**

When pushed it will Reboot the communication port

### **Ethernet Port:**

Allows connection to the inverter system via Ethernet cable

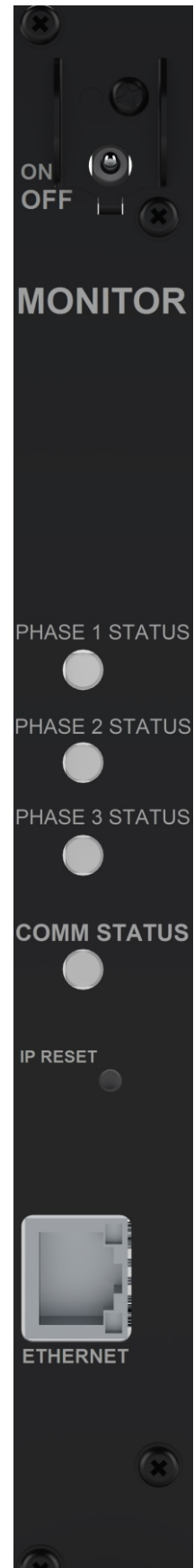

# NC SERIES Part Numbering System

## NC SERIES SYSTEM PART NUMBER

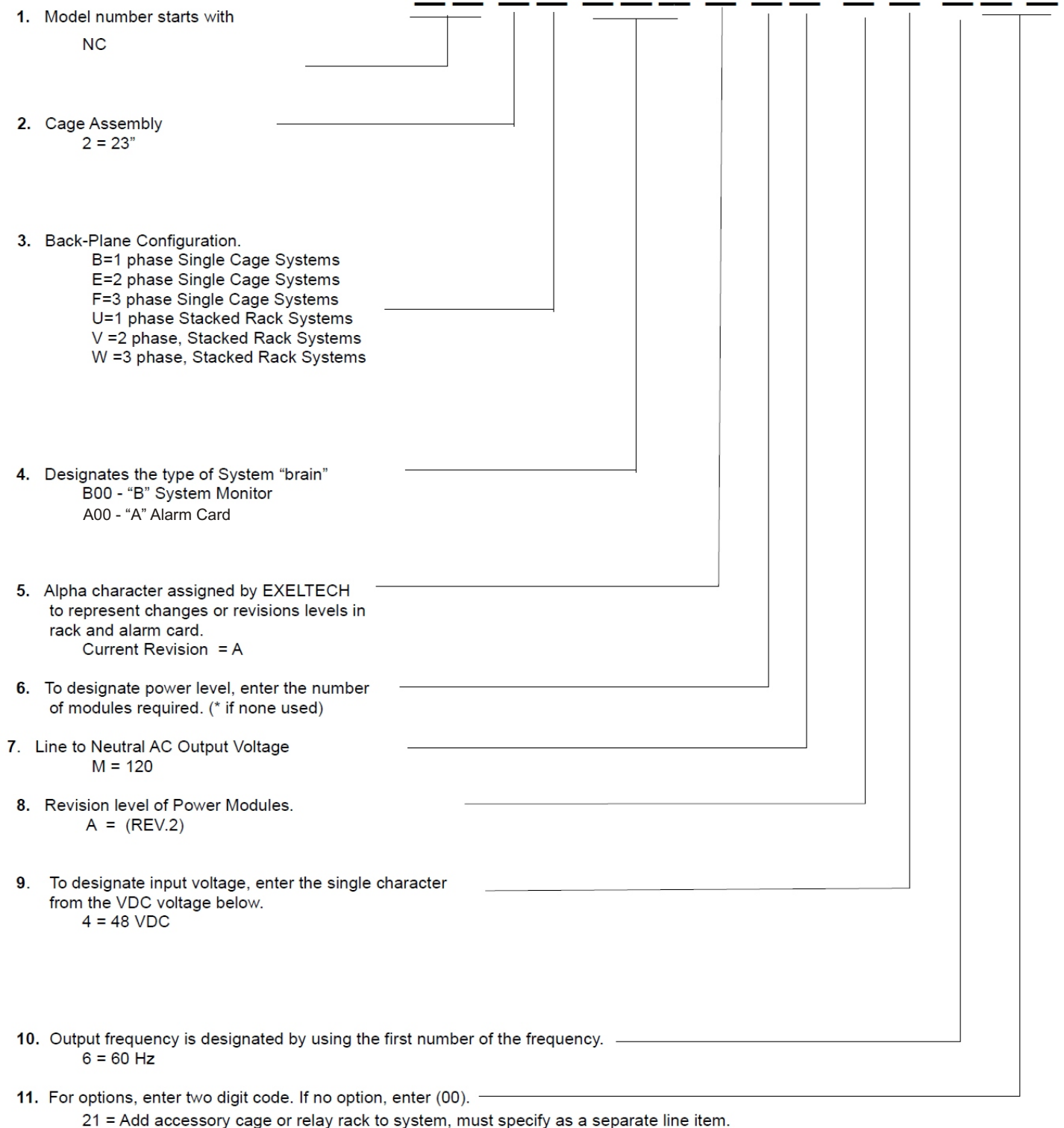

## XO SERIES POWER INVERTERS



EXELTECH manufactures some of the most reliable inverter systems available. Power levels are expandable, and modules can be added or replaced in the field. The XO system can be configured for power levels from 2 to 6KW with 120 VAC output, 240 VAC bi-phase or 208 VAC 3 phase.

The XO system is extremely compact and lightweight. Power modules weigh only 12 lbs each. Output voltage is precisely regulated, so that no measurable voltage change occurs on the output as input voltage fluctuates. Typically, less than 1.2 volt change in output voltage will occur when the output load varies from 0 to 100% of rated power.

- **EXPANDABLE**
- **TRUE SINE WAVE**
- **2000 WATT MODULES**
- **EXTREMELY LIGHTWEIGHT**
- **COMPACT**
- **MICRO PROCESSOR CONTROLLED**

With distortion of 2% maximum, this inverter offers the cleanest sine wave power available. Models are available which cover 24, 48 and 66VDC battery systems. Custom models can be designed to meet your specific input voltage requirements.



America



# XO SERIES POWER INVERTER SPECIFICATIONS

## OUTPUT POWER

CONTINUOUS POWER	SURGE POWER	NO LOAD POWER	OUTPUT VOLTAGE	OUTPUT CURRENT	WEIGHT LBS.
1700W	3400W	12W	100 +/-2%	16.7	15
3400W	6800W	24W	100 +/-2%	16.7	28.6
5100W	10200W	35W	100 +/-2%	16.7	37
2000W	4000W	12W	120 +/-2%	16.7 (15)*	15
4000W	8000W	24W	120 +/-2%	16.7 (15)*	28.6
6000W	12000W	35W	120 +/-2%	16.7 (15)*	37

\*12Vdc Rating- 1800W

## INPUT

MODEL VOLTAGE	MINIMUM (TYPICAL)	SYSTEM (TYPICAL)	MAXIMUM (TYPICAL)	TYPICAL EFFICIENCY @ FULL POWER	PEAK EFFICIENCY @ 1/2 POWER
12V	10.4V	13.8V	15V	> 80%	> 83%
24V	20.8V	27.6V	30V	> 88%	> 90%
48V	41.6V	55.2V	60V	> 88%	> 90%
66V	57.2V	75.9V	82.5V	> 88%	> 90%
108V	93.6V	124.2V	135V	> 88%	> 90%

## GENERAL

CONDITIONS	MINIMUM	TYPICAL	MAXIMUM
WAVEFORM	-	SINUSOIDAL	-
LINE REGULATION	-	.1%	2%
LOAD REGULATION	-	1%	2%
DISTORTION	-	1.5%	2%
FREQUENCY	-.1%	60Hz	+.1%

## PROTECTION CIRCUITRY

Over Voltage: Shutoff at maximum input voltage, per input table.  
 Under Voltage: Shutoff at minimum input voltage, per input table.  
 Thermal: Shuts off due to over temperature condition.  
 Output Short: Unit shuts off: electronically limited. Manual reset required.

## ENVIRONMENTAL

Temperature: -25°C to +25°C full power, derated -17% @ 50°C then 20% per 10°C above 50°C.  
 Humidity: 5 to 95% non-condensing  
 Cooling: Thermostatically controlled variable speed forced air  
 Finish: Powder coated  
 Warranty: Two years parts and labor.

## MECHANICAL

Case size:  
 7" Case HOLDS UP TO 2 MODULES  
 9 inches High  
 18 inches Deep  
 7 inches Wide  
 Weight: 28 lbs.  
 9" Case HOLDS UP TO 3 MODULES  
 9 inches High  
 18 inches Deep  
 9 inches Wide  
 Weight: 37 lbs.

# XO SERIES SYSTEM PART NUMBER

## EXELTECH XO SERIES MODEL NUMBER

\* \* \*

STEP # 1 Model number always starts with XO

STEP # 2 Cage assembly

7	9
7" XO	9" XO

STEP # 3 Configuration

1 phase	2 phase	3 phase
B	E	F

STEP # 4 Enter three asterisks (\*)

STEP # 5 Character assignment by EXELTECH to represent changes or revision levels.

STEP # 6 To designate power level, enter the number or modules required. (\* if none used)

STEP # 7 Enter from the following character code  
Q = 100Vac, M = 120Vac, O = 230Vac

STEP # 8 To designate input voltage, enter the single character from the VDC voltage chart below:

VDC INPUT VOLTAGE CHART			
DC VOLTS	24	48	66
DESIGNATION	2	4	E

STEP # 9 Output frequency is designated by using the first number of the frequency. 5 for 50Hz, 6 for 60Hz, 4 for 400Hz

STEP # 10 Character assigned by EXELTECH to represent revision level of Power Modules.

STEP # 11 For options, enter two digit code. If no option enter (00).

EXAMPLE:      XO9B\*\*\*-3ME6-01

# MI SERIES POWER INVERTERS



- **ULTRA LIGHTWEIGHT**
- **AVAILABLE IN 120, 240 OR 208VAC OUTPUT**
- **12, 24, 48, AND 66VDC INPUT**
- **WEATHER RESISTANT**
- **METERING**
- **2KW, 4KW OR 6KW OUTPUT**

CAGE CODE 00MC3  
NSN 6130-01-492-3067 \* 6KW system

**TL9000**



America

# POWER INVERTER SPECIFICATIONS

## OUTPUT POWER

CONTINUOUS POWER	SURGE POWER	NO LOAD POWER	OUTPUT VOLTAGE	OUTPUT CURRENT per KW	WEIGHT LBS.
4000W	8000W	24W	1 or 2	8.3 A	32
6000W	12000W	35W	1 or 3	8.3 A	42

1 Single phase 120Vac +/- 2%  
 2 Bi-phase 120/240Vac +/- 2%  
 3 3 phase 120/208Vac +/- 2%

## PROTECTION CIRCUITRY

Over Voltage:	Shutoff at maximum input voltage, per input conditions.
Under Voltage:	Shutoff at minimum input voltage, per input table
Thermal:	Shuts off due to over temperature condition.
Output Short:	Unit shuts off: electronically limited. Manual reset required.

## INPUT

MODEL VOLTAGE	MINIMUM (TYPICAL)	SYSTEM (TYPICAL)	MAXIMUM (TYPICAL)	TYPICAL EFFICIENCY @ FULL POWER	PEAK EFFICIENCY @ 1/2 POWER
24V	21V	27.6V	30V	> 88%	> 90%
48V	42V	55.2V	60V	> 88%	> 90%
66V	57.8V	75.9V	82.5V	> 88%	> 90%

## ENVIRONMENTAL

Temperature:	-25°C to +25°C full power, derated -17% @ 50°C then 20% per 10°C above 50°C.
Humidity:	5 to 95% non-condensing
Cooling:	Thermostatically controlled variable speed forced air
Finish:	Powder coated
Warranty:	Two years parts and labor.

## GENERAL

CONDITIONS	MINIMUM	TYPICAL	MAXIMUM
WAVEFORM	-	SINUSOIDAL	-
LINE REGULATION	-	.1%	2%
LOAD REGULATION	-	.3%	2%
DISTORTION	-	1.5%	2%
FREQUENCY*	-.1%	60Hz	+.1%

\*50, 60, 400Hz nominal

## MECHANICAL

Case size:  
 4KW  
 10 inches High  
 11 inches Deep  
 18 inches Wide  
 Weight: 32 lbs.  
 6KW  
 10 inches High  
 14 inches Deep  
 21 inches Wide  
 Weight: 42 lbs.

# FC SERIES/FREQUENCY CONVERTER

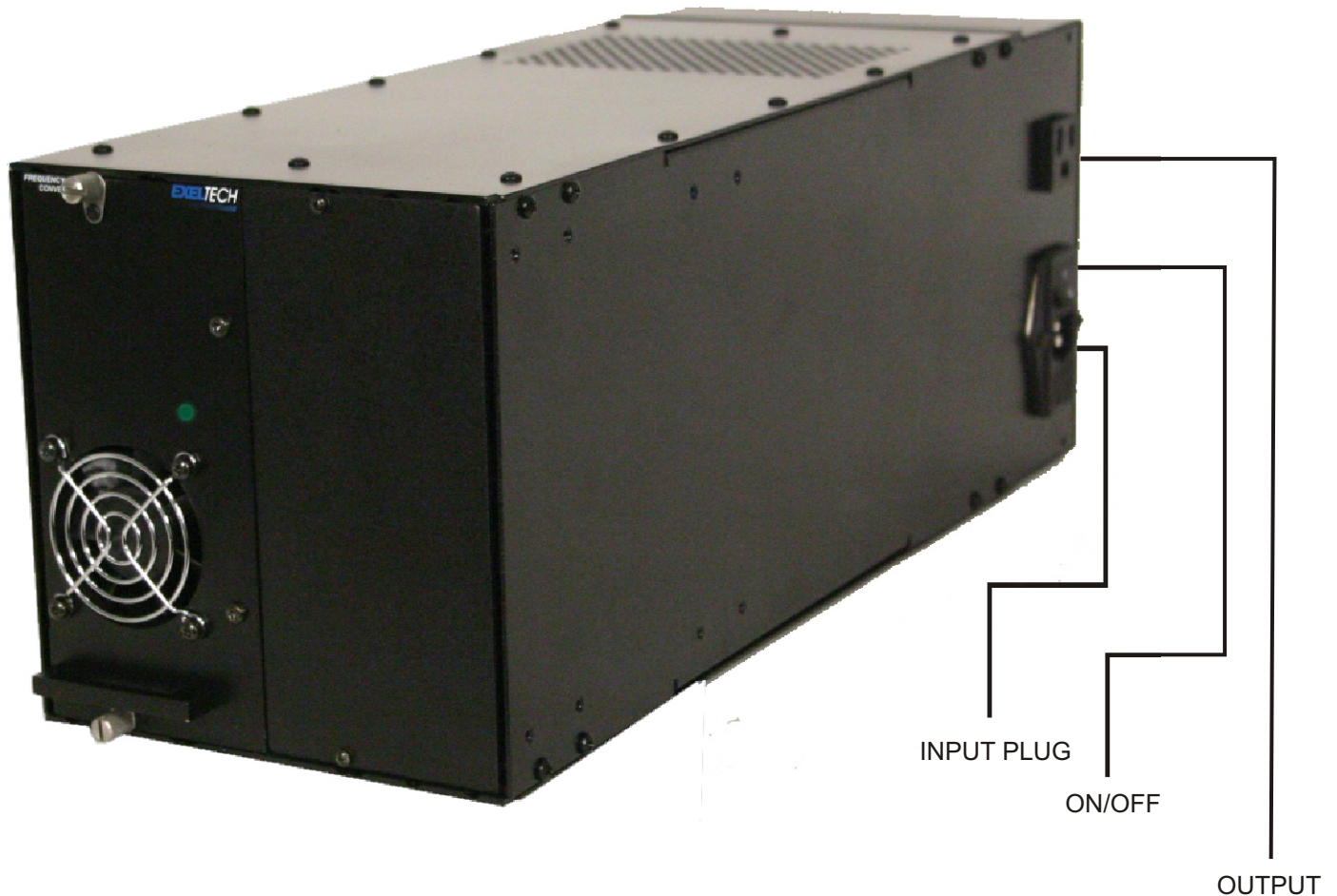

The frequency converter is operated by simply plugging in the supplied cord to the power input, connecting the load to the output plug provided, and turning the unit on. The input and output receptacle, along with the switch, are mounted on the left rear side of the enclosure.

Specifications are listed on the product label regarding maximum input and output voltages and currents.

The unit is protected against thermal and electrical overload. Electrical overloads will cause the AC voltage to collapse as the inverter limits output current. When the overload is removed, output voltage will return to normal. If the output is short circuited, the unit will latch itself off, turning the front LED red. This requires the power switch to be cycled to reset the condition (turn the unit off then back on again). Should the unit be thermally overloaded, too much load at too high a temperature, it will shut off, leaving the fan running. When the internal temperature cools sufficiently the unit will turn itself back on.

When the unit is operating normally, the LED on the front will indicate green.

# FREQUENCY CONVERTER SPECIFICATIONS

## INPUT

Continuous Power	Power Factor	Max Line Regulation	Voltage Range	Freq (Hz)	Module Size	Weight LBS.
500W	>0.98	0.5%	95-260Vac	47-63	A	5.5

## EFFICIENCY

250 - 500W
> 82% @ 120
> 85% @ 230

## OUTPUT

Model	Typical Voltage	Range	Distortion	Load Regulation
120Vac 60 Hz	120	+/- 2%	< 2%	1%
120Vac 50 Hz	120	+/- 2%	< 2%	1%
120Vac 400 Hz	120	+/- 2%	< 3%	3%
230Vac 60 Hz	230	+/- 2%	< 2%	1%
230Vac 50 Hz	230	+/- 2%	< 2%	1%

## Protection Circuitry

Thermal: Shuts off due to over temperature condition.  
 Output: Current limiting with short circuit protection  
 Input: Fuse protected

## Mechanical

Three cages are available, all are 7" high by 18" deep

7 inch: "N" configuration holds 2 power modules  
 19 inch: "N" configuration holds 5 power modules  
 23 inch: "N" configuration holds 6 power modules

Module size "A" - 7" high, 3.2" wide, 15.5" deep

## Environmental

Temperature: -25 to 40 C full power, derated above 40C  
 Altitude: -200 to 10k feet full power, derated above 10k feet  
 Audible noise: > 45dbA  
 Cooling: Thermostatically controlled forced air with variable speed fan  
 Finish: Polyurethane based paint





Manufacturer of True Sine Wave Power Inverters and Related Products

## KC SERIES 1U & 2U POWER INVERTERS



- **EXPANDABLE**
- **REMOTE SWITCHING**
- **TRUE SINE WAVE**
- **“HOT” INSERTABLE**
- **1000 WATT MODULES**
- **OPTIONAL SNMP**

Exeltech’s KC Series inverter systems are available in 19” and 23” rackmount options and are equipped with 1kW power modules. Power modules are “hot” insertable, power levels are expandable, and modules can be added or replaced without interruption in power to your critical loads (At least 3 power modules required).

The KC Series 1U system can be configured for power levels from 1kW to 3kW or 2U stacked configurations with 1kW to 6kW. Systems are single phase with 24VDC, 48VDC, or 108VDC inputs and 120VAC, 277VAC or 230VAC output options available.

A Static Transfer Switch or Monitoring Module plus any number of 1kW power modules combine to make a standard KC Series inverter system. This type of system can be expanded as power requirements increase. The KC Series inverter system can be configured with Exeltech’s 3kW Static Transfer Switch and Maintenance Bypass Switch, to ensure uninterrupted AC supply to sensitive electronic equipment.

Output voltage is precisely regulated, so that no measurable voltage change occurs on the output as input voltage fluctuates. Similarly, less than 0.5 volt change in output voltage will occur when the output load varies from 0 to 100% of rated power. With distortion of 2% maximum, this inverter offers the cleanest sine wave power available.



America



# KC SERIES POWER INVERTER SPECIFICATIONS

## INPUT POWER (PER EACH POWER MODULE)

MODEL VOLTAGE	MINIMUM (TYPICAL)	SYSTEM (TYPICAL)	MAXIMUM (TYPICAL)	TYPICAL EFFICIENCY @ FULL POWER	PEAK EFFICIENCY @ 1/2 POWER
24V	20.8V	27.6V	30V	> 89%	> 91%
48V	41.6V	55.2V	60V	> 89%	> 91%
108V	93.6V	124.2V	135V	> 89%	> 91%

## PROTECTION CIRCUITRY

Over Voltage:	Shutoff at maximum input voltage, per input table.
Under Voltage:	Shutoff at minimum input voltage, per input table.
Thermal:	Shuts off due to over temperature condition.
Output Short:	Unit shuts off: electronically limited. Manual reset required.

## OUTPUT POWER (PER EACH POWER MODULE)

CONTINUOUS POWER	SURGE POWER (3 seconds)	NO LOAD POWER	OUTPUT VOLTAGE	OUTPUT CURRENT	WEIGHT LBS.
1000W	2000W	9W	120V +/-2%	8.3 A	3.8
1000W	2000W	9W	277V +/-2%	3.6 A	3.8
1000W	2000W	9W	230V +/-2%	4.3 A	3.8

## ENVIRONMENTAL

Temperature:	-25°C to +40°C full power, derated -25% per 10°C above 40°C.
Humidity:	5 to 95% non-condensing
Altitude:	-60m to 3,048m (-197ft. To 10,000ft.) Altitudes >10,000ft. thermally derate from 40°C to 30°C.
Cooling:	Thermostatically controlled variable speed forced air.
Warranty:	Full year parts and labor.

## GENERAL

CONDITIONS	MINIMUM	TYPICAL	MAXIMUM
WAVEFORM	-	SINUSOIDAL	-
LINE REGULATION	-	.1%	2%
LOAD REGULATION	-	1%	2%
DISTORTION	-	1.5%	2%
FREQUENCY	-.1%	60Hz	+.1%

## PHYSICAL SPECIFICATIONS

<b>Power Module Dimensions:</b>	1.7" x 7" x 12.7" (H x W x D)
<b>Weight:</b>	3.8 lbs

## MECHANICAL

Two case sizes are available: All are 1.75" high X 16" deep.	
19 inch Wide:	(includes hardware for rack or shelf mounting)
23 inch Wide:	(includes hardware for rack or shelf mounting)

# COMPANY PROFILE

EXELTECH was founded in 1990, based on the philosophy that efficiencies in the manufacturing process through product design, coordinated with facility layout, was paramount to productivity and the key to a quality product. Our mission is to provide leadership electronics and superior customer service through the merging of innovative designs with advanced manufacturing technology.

Quality through design for manufactureability is a primary goal. Utilizing surface mount technology, all design and manufacturing is performed in our facility, located in FORT WORTH, TEXAS. "Pick and place" machines are set up with parts that are standard to all models, allowing for zero setup time and eliminating errors created when reloading or setting up machines. Only large capacitors and magnetics are placed by hand, in an effort to minimize human error through automation. Hand soldering is eliminated through the use of vapor phase reflow. Point to point wiring is eliminated with extensive use of PCB's to perform interconnectivity functions. The use of extruded aluminum for mechanics has reduced the number of nut/bolt and screw points to one-fourth that of previous products, while increasing heat dissipation efficiency and lending a functional form factor to the product.

While design of the products to comply with automated manufacturing processes continues, our people remain the most important part of the quality equation. All employees go through a six month internship before becoming full-time staff members. All employees are cross trained for multi-task capability. Using a PULL system, each station performs a quality check on the performance of the previous station. Data for first time yield and DPU is recorded and analyzed by each station and test bench in an ongoing effort to yield a zero defect process. Upon final assembly, all products then proceed to A.L.T. for "accelerated life testing" to minimize "infant mortality". Packaging and shipping procedures are constantly evaluated to reduce damage.

All repairs are performed at the factory for quality feedback and input for future design. The net result of these philosophies is a line of products that demonstrates an MTBF(mean time between failure) in excess of 20 years and offers the most competitively priced true sine wave inverters available anywhere.

Our commitment to quality and total customer satisfaction has allowed EXELTECH to become innovators in the DC to AC power product market. A few of our "firsts" include; The smallest, lightest high frequency PWM sine wave inverter. The first "N+1" redundant inverter systems, "hot" swappable capability and "modular" design. Our many satisfied customers include AT&T, BROOKHAVEN NATIONAL LABS, DIGITAL EQUIPMENT CORPORATION, MOTOROLA, MCI, GTE GOVERNMENT SYSTEMS and numerous federal and state agencies. We are found quite literally, around the world. We also provide back up power for the communications room in every U.S. Embassy worldwide.

Give us the opportunity to help solve your power problem.

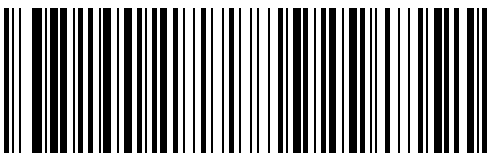

931-\*\*\*CO-0AC



[www.exeltech.com](http://www.exeltech.com)

7317 Jack Newell Blvd North Fort Worth, Texas 76118-7100 voice- 817.595.4969 fax- 817.595.1290 toll free- 800.886.4683

Document subject to change without notice.  
931-\*\*\*CO-0AC