



SB01

SB01 Splice Enclosure

AFL's splice enclosure provides protection from all types of elements. From weather to bullets, the iron and steel construction requires no additional protective covering. Furnished with four plugged cable ports (2 aluminum and 2 plastic) for either All-Dielectric Self-Supporting (ADSS) or Optical Ground Wire (OPGW) cables, the splice enclosure can be pre-mounted to a structure before completion of the splicing phase.

With an internal capacity to store approximately 25 feet of buffer tube, the closure is more cost-effective, eliminating the need for an external coil storage bracket (with exception to stainless steel tube optical ground wire designs). The 72-fiber circular fiber tray, constructed of high impact-resistant Lexan®, enables management of up to 144 fibers. The tray's black base and clear lid enable easy accessibility.

Ideal for electric utilities and optical cable installers, the splice enclosure is versatile and cost-effective for new and existing installations.

Features

- Up to 144-fiber splice capacity, depending on cable design
- Customizable kit with no special re-entry kits required
- Splice tray constructed of high impact-resistant Lexan®
- Manufactured of iron and steel; bullet-resistant
- Pre-mountable enabling easy re-entry and access
- Unique new gasket with top-center radius eliminates the need for RTV sealant
- New C11508-1 gasket can be retrofitted to existing splice closures



SB01 with 12 splice capacity tray



SB01 with 72 splice capacity tray



Top view of new SB01 gasket (AFL No. C11508-1)

Ordering Instructions – Step 1

DESCRIPTION	AFL NO.
Splice Enclosure including one splice tray for 12 single fused fiber capacity, sealant, organizer tray for additional trays.	SB01
Splice Enclosure including one splice tray for 72 single fused fiber capacity. Protection sleeves not included.	SB01-72
Splice Enclosure including two splice trays for 72 single fused fiber capacity, a total of 144 splices. Protection sleeves not included.	SB01-144

Cable connector kits required to complete installation are sold separately. Refer to "Ordering Instructions" Steps 2 and 3 on the following pages to complete your order.

Ordering Instructions – Step 2

CONNECTOR KIT	APPLICATION
SLCK, SCK, APCK	Optical Ground Wire
BCK	All-Dielectric Self-Supporting (ADSS) Fiber Optic Cable Loose Tube Fiber Optic Cable

Refer to page on connector kits for AFL number set-up.

continued
→

SB01 Splice Enclosure (cont.)

Specifications

PARAMETER	VALUE
Maximum Tray Capacity (depending on tray type)	4 ST1 Trays or 2 ST72 Trays
Maximum Fiber Count (depending on tray type)	48 with ST1; 144 with (2) ST72
Weight	52 lbs. (23.57 kg)
Diameter	14.56 in. (370 mm)
Height (with cover)	5.25 in (133.35 mm)
Mounting Distance (hole to hole)	17.88 in (454.15 mm)

Dimensions

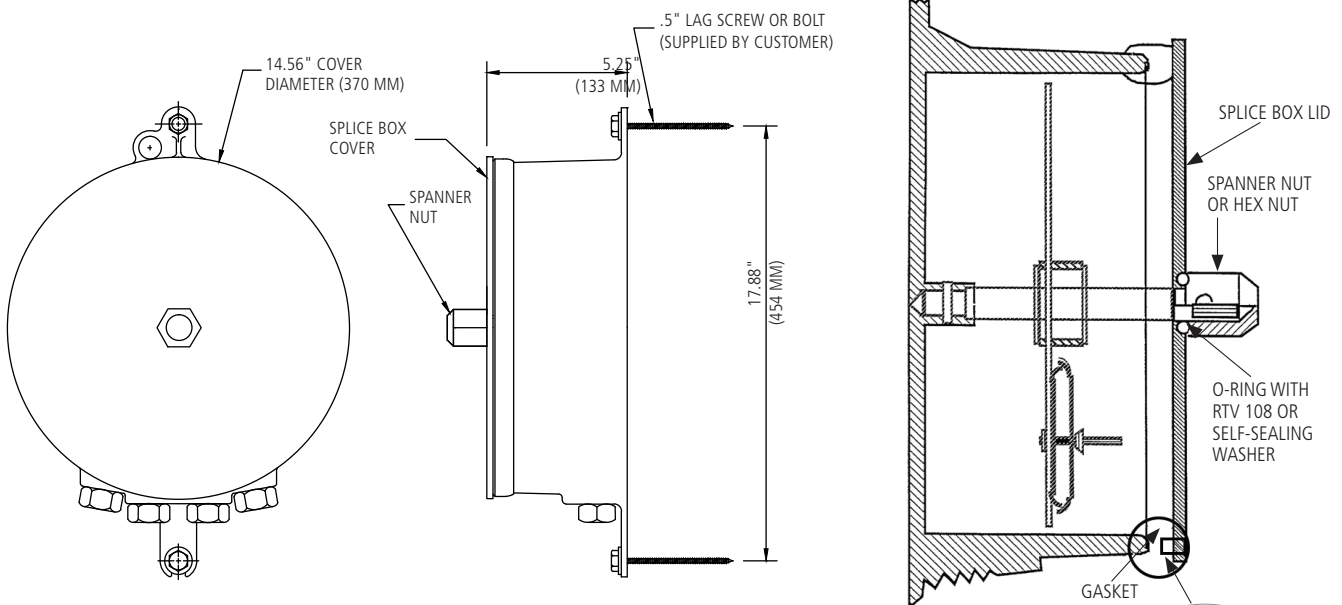

NOTE: Banding and steel tower adapters are available in lieu of bolts.

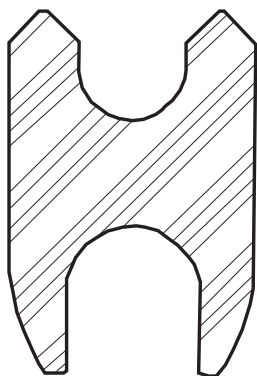

Old Gasket Design

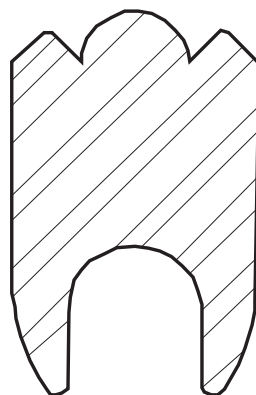

New Gasket Design
(AFL No. C11508-1)

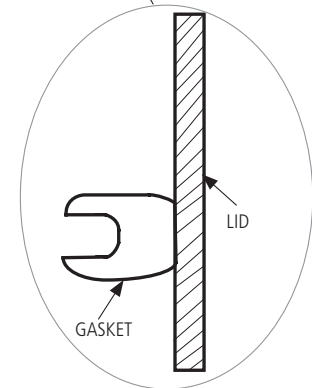

continued →

Connector Kits for Opti-Guard and SB01 Splice Enclosures—OPGW Cable

Connector Kit: Optical Ground Wire

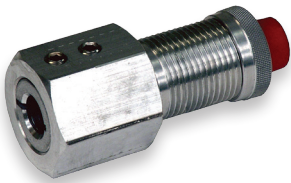

Optical Ground Wire Connector Kit

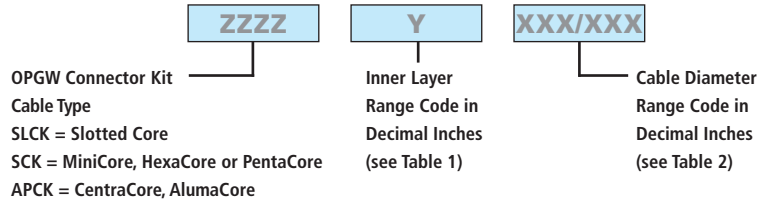

Ordering Example: For 0.571" diameter SX-67/49/571, which has a layer 1 total diameter of 0.358", the AFL number is SCKB569/583.

Table 1 – Inner Layer Range Codes

RANGE CODE	 SLOTTED CORE DIAMETER	 MINICORE, HEXACORE OR PENTACORE LAYER 1 DIAMETER	 CENTRACORE OR ALUMACORE PIPE DIAMETER
A	0.185 - 0.227	0.000 - 0.230	0.185 - 0.227
B	0.228 - 0.264	0.231 - 0.500	0.228 - 0.264
C	0.265 - 0.300	0.501 - 0.636	0.265 - 0.300
D	0.301 - 0.374	—	0.301 - 0.374
E	0.375 - 0.479	—	0.375 - 0.479
F	0.480 - 0.550	—	0.480 - 0.550
G	0.551 - 0.630	—	0.551 - 0.630
H	0.631 - 0.700	—	0.631 - 0.700

Table 2 – Cable Diameter Range Codes

RANGE CODE	CABLE DIAMETER RANGE	
	MIN.	MAX.
225/240	0.225	0.240
241/255	0.241	0.255
256/271	0.256	0.271
272/286	0.272	0.286
287/302	0.287	0.302
303/318	0.303	0.318
319/333	0.319	0.333
334/349	0.334	0.349
350/365	0.350	0.365
366/380	0.366	0.380
381/396	0.381	0.396
397/412	0.397	0.412
413/427	0.413	0.427
428/443	0.428	0.443
444/459	0.444	0.459
460/474	0.460	0.474
475/490	0.475	0.490

RANGE CODE	CABLE DIAMETER RANGE	
	MIN.	MAX.
491/506	0.491	0.506
507/521	0.507	0.521
522/537	0.522	0.537
538/553	0.538	0.553
554/568	0.554	0.568
569/583	0.569	0.583
584/599	0.584	0.599
600/615	0.600	0.615
616/630	0.616	0.630
631/646	0.631	0.646
647/662	0.647	0.662
663/677	0.663	0.677
678/693	0.678	0.693
694/708	0.694	0.708
709/727	0.709	0.727
728/740	0.728	0.740

continued →

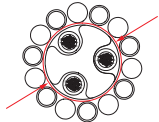
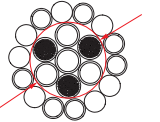
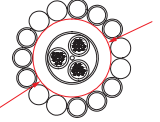
Connector Kits for Opti-Guard and SB01 Splice Enclosures— Black Jacket Cable

Connector Kit: All-Dielectric Self-Supporting Fiber Optic Cable

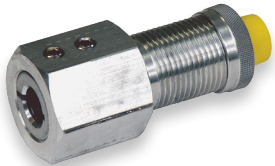

All-Dielectric Self-Supporting Connector Kit

BCK

Black Jacket Cable
Connector Kit

XXX/XXX

Range Code in
Decimal Inches
(see Table 1 below)

F

Blank = No Additional Connector
Assembly Required
F = 1" Flex Conduit Connector Required

Ordering Example: For 0.528" diameter ADSS, the AFL number is BCK522/537.

Connector Kit: Loose Tube Fiber Optic Cable

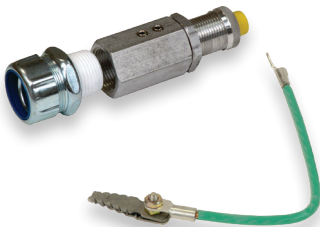

Armored Loose Tube Connector Kit

BCK

Black Jacket Cable
Connector Kit

XXX/XXX

Range Code in
Decimal Inches
(see Table 1 below)

B

Options
Blank = No Additional Connector
Assembly Required
F = 1" Flexible Conduit Connector Required
A = Armor Ground Assembly Required
B = Armor Ground Assembly and 1" Flexible
Conduit Connector Required

Ordering Example: For 0.510" armored loose tube (duct) cable with flexible conduit and armor ground connections, the AFL number is BCK507/521B.

Table 1

RANGE CODE	CABLE DIAMETER RANGE	
	MIN.	MAX.
225/240	0.225	0.240
241/255	0.241	0.255
256/271	0.256	0.271
272/286	0.272	0.286
287/302	0.287	0.302
303/318	0.303	0.318
319/333	0.319	0.333
334/349	0.334	0.349
350/365	0.350	0.365
366/380	0.366	0.380
381/396	0.381	0.396
397/412	0.397	0.412
413/427	0.413	0.427
428/443	0.428	0.443
444/459	0.444	0.459
460/474	0.460	0.474
475/490	0.475	0.490

RANGE CODE	CABLE DIAMETER RANGE	
	MIN.	MAX.
491/506	0.491	0.506
507/521	0.507	0.521
522/537	0.522	0.537
538/553	0.538	0.553
554/568	0.554	0.568
569/583	0.569	0.583
584/599	0.584	0.599
600/615	0.600	0.615
616/630	0.616	0.630
631/646	0.631	0.646
647/662	0.647	0.662
663/677	0.663	0.677
678/693	0.678	0.693
694/708	0.694	0.708
709/727	0.709	0.727
728/740	0.728	0.740

continued →

SB01 Splice Enclosures Accessories

Ordering Instructions – Step 3

The SB01 includes accessories that allow for up to 12 fiber splices. Additional components shown below may be ordered when more than 12 splices are required.

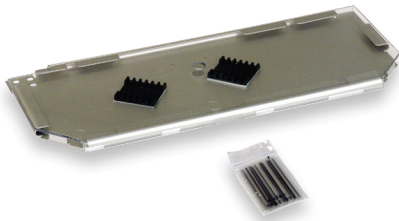

Splice Tray

The SB01 Splice Tray organizes and protects the fiber splices.

Features

- 12 single-fused fiber splice capacity
- Includes 13 splice protection sleeves

Ordering Information

MODEL	AFL NO.
SB01 Splice Tray	ST1



TT1 Transition Tray

The SB01 Transition Tray is used to divide fibers into groups for routing into splice trays. To be used for OPGW cables containing stainless steel tubes.

Features

- 48 fiber capacity
- Used in conjunction with SB01 Furcation Kit
- Not required for ST1-72 tray
- Not required with AlumaCore OPGW designs

Ordering Information

MODEL	AFL NO.
SB01 Transition Tray	TT1



72 Fiber Splice Tray

The 72 Fiber Splice Tray is used to organize and protect up to 72 single fused fibers in the SB01 splice enclosure.

Features

- 72 single-fused fiber splice capacity
- Protection sleeves sold separately

Ordering Information

MODEL	AFL NO.
72 Fiber Splice Tray	ST1-72



SB01 Furcation Kit

The SB01 Furcation Kit includes the materials required to properly divide fibers into groups inside the SB01 splice enclosure.

Features

- Contains tubing to protect and guide fibers inside the splice enclosure
- Includes cable ties to secure buffer tubes to the splice tray

Ordering Information

MODEL	AFL NO.
SB01 Furcation Kit	SB01FK